

WOOD PANEL J-MOLD

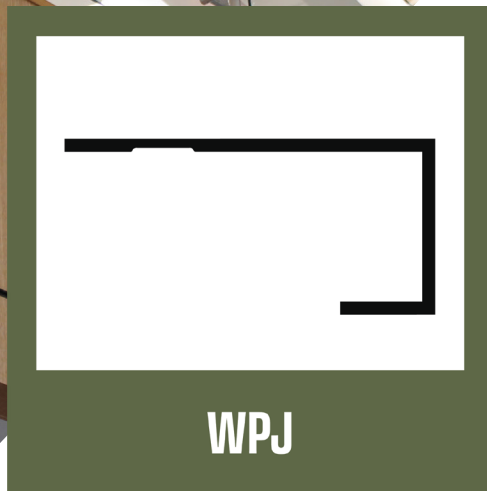

APPLICATION

Flannery's Wood Panel J-Mold is an edge trim, which helps finish millwork panels that terminate against dissimilar materials such as doors or windows.

SPECIFICATION

- Standard extruded aluminum alloy 6063 T5
- Typical .050" nominal wall thickness or greater
- Come in 10-foot lengths
- Stocked in Clear Anodized and Mill Finish (for field painting and priming) and some Black Anodized and Factory Primed
- Other factory finishes and custom paint are available

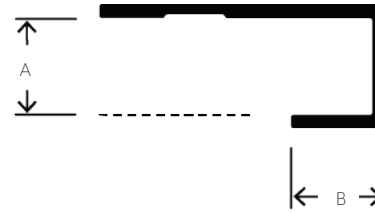

PART NO.	"A" DEPTH	"B" WIDTH	PANEL SIZE
CPJ 375-375	3/8"	3/8"	3/8"
CPJ 50-375	1/2"	3/8"	1/2"
SJM 460-50	29/64"	1/2"	29/64"
SJM 625-100	5/8"	1"	5/8"
WPJ 75-375	3/4"	3/8"	3/4"
WPJ 75-50	3/4"	1/2"	3/4"
SJM 80-50	4/5"	1/2"	4/5"
SJM 875-100	7/8"	1"	7/8"
SJM 1063-375	1 1/16"	3/8"	1 1/16"
SJM 1125-1250	1 1/8"	1 1/4"	1 1/8"
SJM 1250-50	1 1/4"	1/2"	1 1/4"
WPJ 1417-188	1 13/32"	3/16"	1 13/32"

INSTALLATION DETAIL

Attach Flannery's Wood Panel J-Mold to the framing with nails, screws or approved fastening methods.

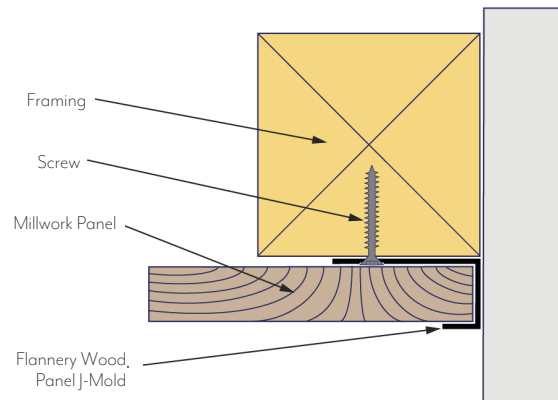

SPECIFICATIONS FOR MILLWORK PANEL TRIM

PRODUCT SPECIFICATIONS

Flannery recommends that any installer of Aluminum Panel Trims properly layout and coordinate the installation of trims along with the millwork paneling that will be utilized in a given installation. Proper planning will reduce installation time and produce the desired design aesthetic.

INSTALLATION INSTRUCTIONS FOR MILLWORK TRIM

1. Flannery's Millwork Panel Trims must be installed in a planned order to avoid installation errors. Projects should be started at one of the lower side elevations and move up and over as the wall pattern is laid out.
2. Framing should provide a backer so that moldings can be attached with approved fastening methods at 16" or 24" on center.

MILLWORK TRIM ALLOY & COMPOSITION

Flannery's Panel Trims are standard extruded aluminum alloy 6063 T5 and have a typical .050" nominal wall thickness. Aluminum Panel Trims are aesthetic trims which are not intended to hold or support the weight of any panel system. Please consult a structural engineer when considering the use of Flannery Furring Strips or Z-Fur Strips in a rainscreen system.

GENERAL SPECIFICATIONS FOR FLANNERY TRIMS

PRODUCT SPECIFICATIONS

Flannery recommends that any installer of our Aluminum Trims properly layout and coordinate the installation of trims along with materials that will be utilized in the installation of the exterior wall system.

FLANNERY ALUMINUM TRIM ALLOY & COMPOSITION

Flannery's Aluminum Trims are standard extruded aluminum alloy 6063 T5 and have a typical .050" or greater nominal wall thickness. Extruded Aluminum Trims are aesthetic trims which are not intended to hold or support the full weight of any Panel, Stucco, or Plaster system. Flannery's Trims meet or exceed ASTM B221 for extruded aluminum products.

Flannery's Aluminum Trims come in 10' lengths typically and shall have a standard stock finish of Mill Finish (for field priming & painting) or Clear Anodized (some may be stocked in Black Anodized). Other factory finishes including liquid or powder coated paint, Chem-Film, Primer and special Anodizing finishes are available. All of our other finishing options can be viewed on the next page.

HANDLING ALUMINUM TRIMS

Personal protection equipment should be utilized when handling and installing aluminum trims. Gloves and eye protection must be worn when handling aluminum trims as well as ear protection when cutting.

CUTTING ALUMINUM MOLDINGS

Flannery recommends that ten-foot lengths be used wherever possible. Aluminum Moldings can be cut with a chop saw, using a 125-150-tooth carbide-tip blade for non-ferrous metal. An abrasive cut-off wheel should not be used to cut aluminum trims. Blade lubricant (WD-40 or grease stick) must be applied to the blade before each cut. Lubricant should be cleaned from the trim prior to installation.

STEPS FOR FIELD PAINTING MILL FINISH (RAW) ALUMINUM MOLDINGS

1. Clean and treat moldings in accordance with the paint manufacturer's specifications.
2. Use a primer recommended by the paint manufacturer's specifications.
3. Apply the paint coat according to the paint manufacturer's specifications.
4. Flannery makes no guarantees, nor accepts any responsibility, for the performance of field-applied coatings over anodized finishes.
5. If aluminum trim has an alternate finish, contact Flannery for field painting instructions.

PLEASE NOTE

This product sheet presents general guidelines and suggestions for the installation of Flannery trims and products. The purpose of these general guidelines and suggestions is to aid in a successful interior or exterior finish based on the Uniform Building Code and industry standards. No one catalog or product guide can address all of the unique specifics or installation details that occur from one project to another. Flannery recommends that every installer be familiar, or become acquainted with, common interior or exterior trim installation practices before installing any of Flannery's many trims and products. Flannery also recommends that the specifying architect, engineer, and general contractor be consulted with as well.