

PLASTER F-MOLD

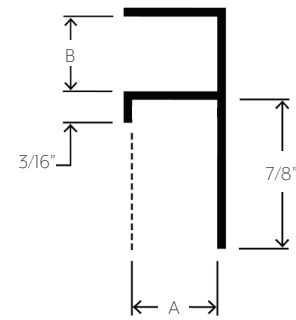
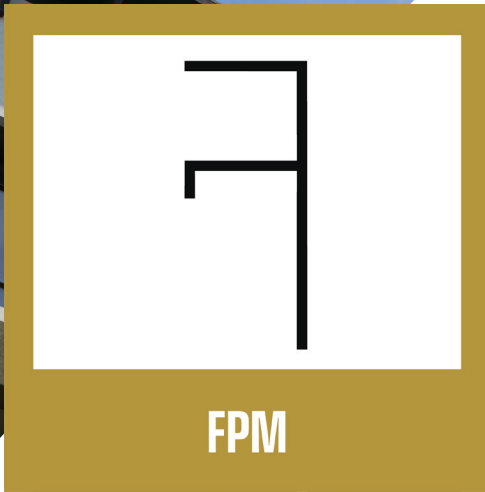

APPLICATION

Flannery's Plaster F-Mold creates an aesthetic termination reveal in any stucco wall system. Typically installed where a stucco wall terminates at an opposing wall or dissimilar material, the Plaster F-Mold can act as a stucco stop with a built in reveal.

SPECIFICATION

- Standard extruded aluminum alloy 6063 T5
- Typical .050" nominal wall thickness or greater
- Come in 10-foot lengths
- Stocked in Clear Anodized and Mill Finish (for field painting and priming)
- Chem-film, other factory finishes and custom paint are available

PART NO.	"A" DEPTH	"B" WIDTH
FPM 50-25*	½"	¼"
FPM 50-50	½"	½"
FPM 50-75	½"	¾"
FPM 50-100*	½"	1"
FPM 50-150*	½"	1 ½"
FPM 50-200	½"	2"
FPM 50-250*	½"	2 ½"
FPM 50-300*	½"	3"
FPM 50-400*	½"	4"
FPM 50-600*	½"	6"
FPM 625-50	⅝"	½"
FPM 625-75	⅝"	¾"
FPM 625-100	⅝"	1"
FPM 625-150*	⅝"	1 ½"
FPM 625-200	⅝"	2"
FPM 625-300*	⅝"	3"
FPM 625-400*	⅝"	4"
FPM 75-25	¾"	¼"
FPM 75-50	¾"	½"
FPM 75-75	¾"	¾"
FPM 75-100	¾"	1"
FPM 75-150	¾"	1 ½"
FPM 75-200	¾"	2"
FPM 75-250*	¾"	2 ½"
FPM 75-300	¾"	3"
FPM 75-400	¾"	4"
FPM 75-600*	¾"	6"

*Indicates Modified Part

PLASTER F-MOLD

INSTALLATION DETAIL

Install all Plaster F-Molds using full ten-foot lengths wherever possible. Attach Plaster F-Molds over the weather resistant barrier (WRB) to the framing with nails, screws, or other approved fastening methods. A shi lap of building paper or WRB may need to be installed over the attachment flange if the Plaster F-Mold is being used as a stucco stop. All Plaster Trims must be cut accurately and installed with tight, neat joints. All nailing flanges must be covered with lath and all butt joints must be sealed. Manufacturer recommends that a carbide tip blade along with lubricant be used when cutting any aluminum trims.

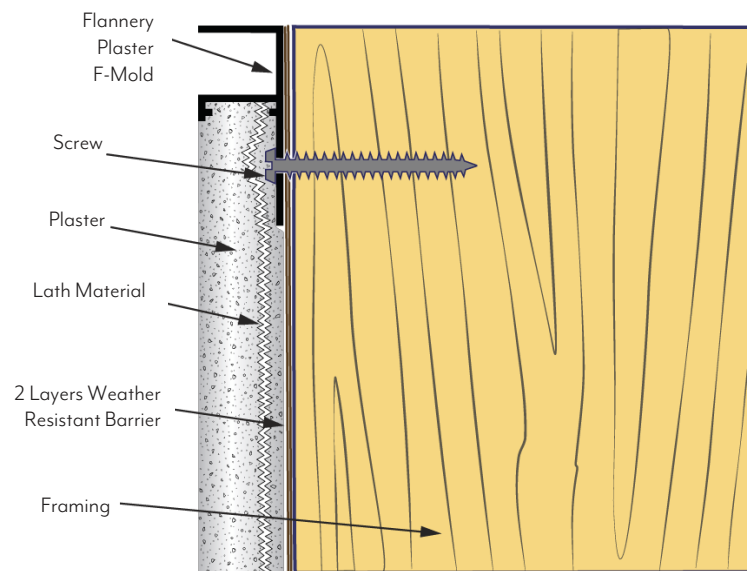

PLASTER F-MOLD CUSTOM FABRICATION

CORNERS & INTERSECTIONS

Plaster F-Mold prefabricated factory intersections and corners can be manufactured with the same or different moldings. They are used to complete intricate building designs that utilize intersecting lines (both vertical and horizontal) around interior or exterior walls. The intersections and corners are mitered and then heli-arc welded at the installation flanges. A seal is then applied to the back of the intersecting butt joints. The standard intersection or corner comes with 6" legs from the center point of the reveal but custom leg lengths are also available. All installation flanges must be covered with lath and all butt joints must be sealed.

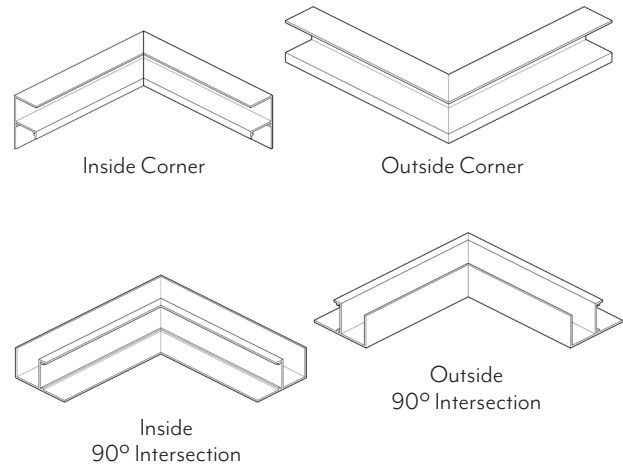

RADIUS

Radius Shapes are factory curved or bent pieces of material that are necessary when Plaster F-Mold trim runs along a "curved" or "radiused" plane. Radiused material is bent to a project's dimensional requirements and is considered a custom product.

Here are some things you should consider when ordering Plaster F-Mold Radius:

- Radius Shapes are formed from 10' pieces of material. Usually, only 9' of that material will be usable for installation due to machining marks.
- Radius Order Forms can be downloaded at flannerytrim.com.

When placing an order for radius with Flannery, please indicate the following:

1. Product Type (product code and finish required).
2. Direction of Bend (Inside Curve, Outside Curve, Arch, or Reverse Arch).
3. Size of Radius (in inches or feet).
4. Point of Measurement (the point on the trim where the radius is measured to).
5. Quantity of Pieces Required.

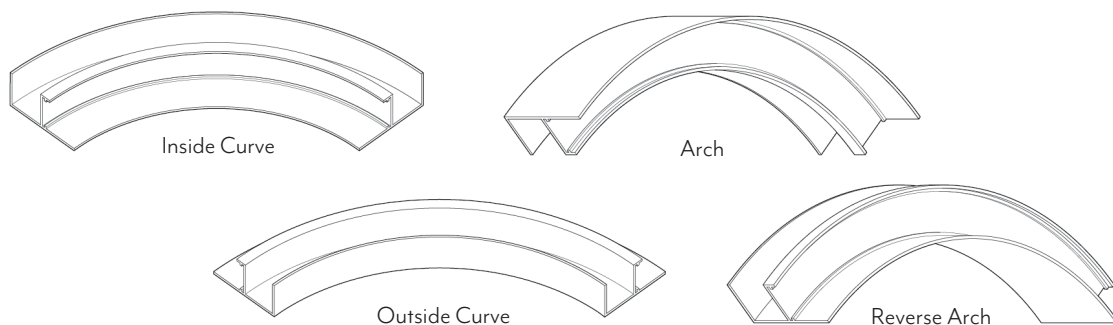

ACCESSORIES FOR PLASTER & STUCCO TRIMS

ALIGNMENT SPLICES

Many of Flannery's Plaster Trims are available with our exclusive Aluminum Alignment Splices. Flannery offers our Straight Splices free of charge and our Special Corner or 90° Intersection splices for a small charge. Straight Splices assist the installer in aligning and joining aluminum trims together along a straight plane. Installers who cut their own miters in the field can use our Special Corner and 90° Intersection Splices to bring the cut pieces together for a tight and clean butt/miter joint.

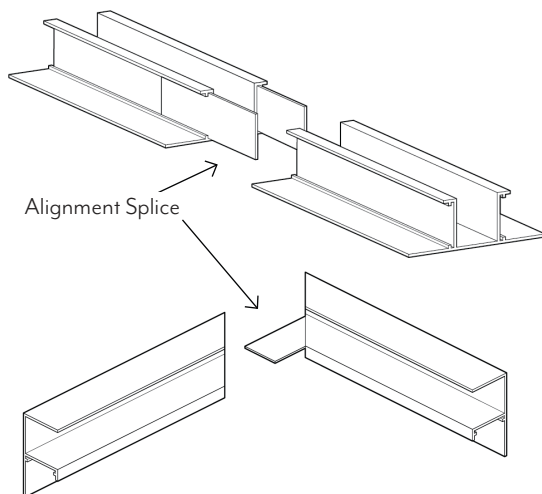

CHANNEL END CAPS

Flannery offers Channel End Caps for all sizes of the Plaster Channel Screeds and other reveals. End Caps create a termination point for any reveal where the channel may terminate against a dissimilar material such as a door or window frame. They can also be used when a channel terminates in the middle of a plaster wall.

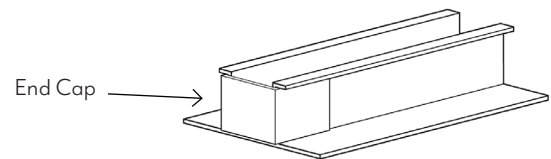

SPECIFICATIONS FOR PLASTER & STUCCO TRIMS

INSTALLATION INSTRUCTIONS FOR EXTERIOR REVEAL MOLDINGS INSTALLED VERTICALLY

1. Building Paper must be placed behind all moldings and have a shi lap of 6”.
2. Attach moldings 16” on center to framing using approved fastening methods. Butt joints must be cut accurately and sealed.
3. Install lath over installation flanges of all moldings.
4. Mask all reveals prior to plastering. Use cloth or vinyl tape specifically manufactured for masking anodized aluminum moldings. For painted moldings, use vinyl tape.

INSTALLATION INSTRUCTIONS FOR EXTERIOR REVEAL MOLDINGS INSTALLED HORIZONTALLY

1. Building paper must be placed behind all moldings and have a shi lap of at least 2”.
2. Attach moldings 16” or 24” on center to framing using approved fastening methods. Butt joints must be cut accurately and sealed.
3. Install lath over installation flanges of all moldings.
4. Mask all reveals prior to plastering. Use cloth or vinyl tape specifically manufactured for masking anodized aluminum moldings. For painted moldings, use vinyl tape.

INSTALLATION INSTRUCTIONS FOR EXTERIOR REVEAL MOLDINGS OVER METAL LATH

1. Molding selection must be in accordance with the proper plaster thickness specified.
2. Moldings must be tied to the lath with tie wire, thus protecting the waterproof membrane. Flannery offers factory punched stucco “key” holes along the reveal attachment flanges to assist in tying the trim to the metal lath or wire. Butt joints must be cut accurately and sealed.
3. All installation flanges of the moldings must be covered with lath.
4. Please note that the Uniform Building Code requires two layers of grade “D” paper when applied over wood-based sheathing.
5. Mask all reveals prior to plastering. Use cloth or vinyl tape specifically manufactured for masking anodized aluminum moldings. For painted moldings, use vinyl tape.

GENERAL SPECIFICATIONS FOR FLANNERY TRIM

PRODUCT SPECIFICATIONS

Flannery recommends that any installer of our Aluminum Trims properly layout and coordinate the installation of trims along with materials that will be utilized in the installation of the exterior wall system.

FLANNERY ALUMINUM TRIM ALLOY & COMPOSITION

Flannery's Aluminum Trims are standard extruded aluminum alloy 6063 T5 and have a typical .050" or greater nominal wall thickness. Extruded Aluminum Trims are aesthetic trims which are not intended to hold or support the full weight of any Panel, Stucco, or Plaster system. Flannery's Trims meet or exceed ASTM B221 for extruded aluminum products.

Flannery's Aluminum Trims come in 10' lengths typically and shall have a standard stock finish of Mill Finish (for field priming & painting) or Clear Anodized (some may be stocked in Black Anodized). Other factory finishes including liquid or powder coated paint, Chem-Film, Primer and special Anodizing finishes are available. All of our other finishing options can be viewed on the next page.

HANDLING ALUMINUM TRIMS

Personal protection equipment should be utilized when handling and installing aluminum trims. Gloves and eye protection must be worn when handling aluminum trims as well as ear protection when cutting.

CUTTING ALUMINUM MOLDINGS

Flannery recommends that ten-foot lengths be used wherever possible. Aluminum Moldings can be cut with a chop saw, using a 125-150-tooth carbide-tip blade for non-ferrous metal. An abrasive cut-off wheel should not be used to cut aluminum trims. Blade lubricant (WD-40 or grease stick) must be applied to the blade before each cut. Lubricant should be cleaned from the trim prior to installation.

STEPS FOR FIELD PAINTING MILL FINISH (RAW) ALUMINUM MOLDINGS

1. Clean and treat moldings in accordance with the paint manufacturer's specifications.
2. Use a primer recommended by the paint manufacturer's specifications.
3. Apply the paint coat according to the paint manufacturer's specifications.
4. Flannery makes no guarantees, nor accepts any responsibility, for the performance of field-applied coatings over anodized finishes.
5. If aluminum trim has an alternate finish, contact Flannery for field painting instructions.

PLEASE NOTE

This product sheet presents general guidelines and suggestions for the installation of Flannery trims and products. The purpose of these general guidelines and suggestions is to aid in a successful interior or exterior finish based on the Uniform Building Code and industry standards. No one catalog or product guide can address all of the unique specifics or installation details that occur from one project to another. Flannery recommends that every installer be familiar, or become acquainted with, common interior or exterior trim installation practices before installing any of Flannery's many trims and products. Flannery also recommends that the specifying architect, engineer, and general contractor be consulted with as well.