



Flannery, Inc
Specialty Aluminum Trims

EXTERIOR TRIM

PLASTER & STUCCO TRIMS

SOFFIT VENTILATION TRIMS

EXTERIOR PANEL TRIMS

flannerytrim.com - 682.207.2650

OUR STORY

2025 represents Flannery's 50th year of trim manufacturing. Over the past five decades we have manufactured steel, vinyl, and aluminum products for every aspect of the wall and ceiling industry. There are very few wall systems, whether interior or exterior, where our trims cannot be found.

Beginning in 1975, an "old lath and plasterer" put down his tool bag after two decades in the field, went into his garage and built a specialty trim company. Barry "Bud" Rutherford produced over 12 patents of drywall and plaster trim products that we still sell today.

Building on the legacy of Bud Rutherford, Flannery has grown to become the premier manufacturer of aluminum trims. It continues to be a family-owned and operated business that has a diverse product line for both interior and exterior walls and ceiling applications. Our full production facility boasts one of the largest product inventories of niche extruded aluminum construction trims.

In addition, Flannery is dedicated to providing the necessary technical assistance and customer service that will enable any builder, architect, or owner to succeed in their building design. Contact us today for help with any trim solution by emailing us at info@flannerytrim.com or visit our website.

TABLE OF CONTENTS

Plaster & Stucco Trims	4-20
Shapefinder	4-5
Reveals	6-9
Stucco Stops	10-15
Corners	16
Welded Intersections & Corners	17
Factory Radius	18
Specifications	19-20
Soffit Ventilation Trims	21-29
Shapefinder	21
Plaster Vents	22-25
EIFS Vents	26-27
Specifications	29
Exterior Panel Trims	30-43
Shapefinder	30-31
Vertical Reveals	32-33
Horizontal Reveals	34
Furring Strips	35
Terminations	36-37
Door & Window Trims	38
Outside Corners	39
Inside Corners	40-41
Specifications	42
Manufacturer's Specifications	43
Factory Finishes	44-45

PLASTER & STUCCO TRIM SHAPEFINDER



6

2-PIECE EXPANSION REVEAL

In this section you will find Flannery's complete line of exterior Plaster and Stucco trims to complement both commercial and residential construction. Trims vary from typical plaster reveals to plaster stops and drip screeds. While most of the trims were built for Three-Coat stucco, we also carry the proper trim depths to accommodate One-Coat and Exterior Insulation and Finish Systems (EIFS). Be sure to review pages 17-18 for our factory fabrication capabilities, including radius and welded intersections for our Plaster and Stucco Trims.



6

SMOOTH FINISH CHANNEL



7

PLASTER CHANNEL SCREED

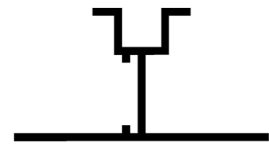

8

PLASTER CONTROL JOINT

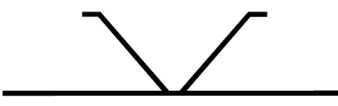

8

DEEP V-REVEAL



8

SHORT V-REVEAL



9

WEEPING REVEAL



9

EXPANSION WEEP



10

PLASTER F - MOLD



11

SMOOTH FINISH F - MOLD

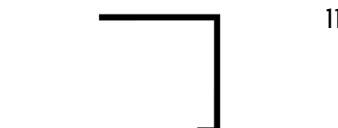

11

PLASTER J - MOLD

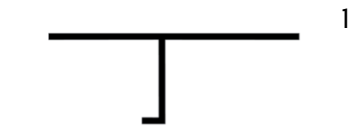

12

PLASTER T - MOLD

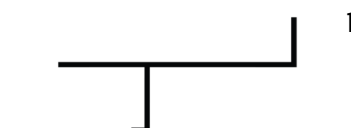

12

SOFFIT W-MOLD

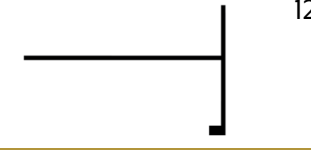

12

FASCIA CORNER MOLD

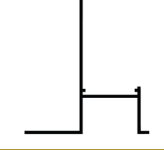

13

DRIP SCREED



13

2-PIECE DRIP SCREED

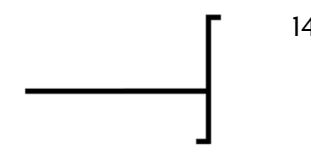

14

PLASTER WINDOW RETURN

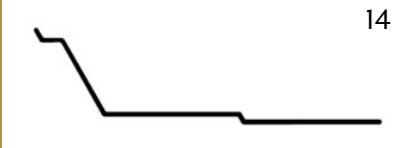

14

SELF-WEEPING WINDOW DRIP



14

ALUMINUM WEEP SCREED



15

PLASTER PARAPET CAP

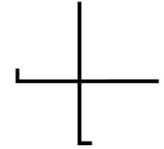

16

PLASTER X-MOLD

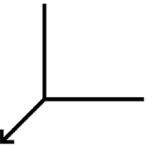

16

PLASTER CORNER MOLD



2-PIECE EXPANSION REVEAL

Flannery's 2-Piece Expansion Reveal acts as a plaster expansion joint designed to allow for the minor movement that may occur within an interior or exterior stucco finish. The Expansion Reveal creates an aesthetic reveal like a Channel Screed and allows for a 1/4" of movement.

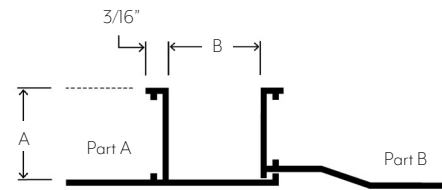

PART NO.	"A" DEPTH	"B" WIDTH
EXP 50-50	1/2"	1/2"
EXP 50-75	1/2"	3/4"
EXP 50-100	1/2"	1"
EXP 75-25*	3/4"	1/4"
EXP 75-50	3/4"	1/2"
EXP 75-75	3/4"	3/4"
EXP 75-100	3/4"	1"
EXP 75-150*	3/4"	1 1/2"
EXP 75-200*	3/4"	2"

*Indicates Modified Part

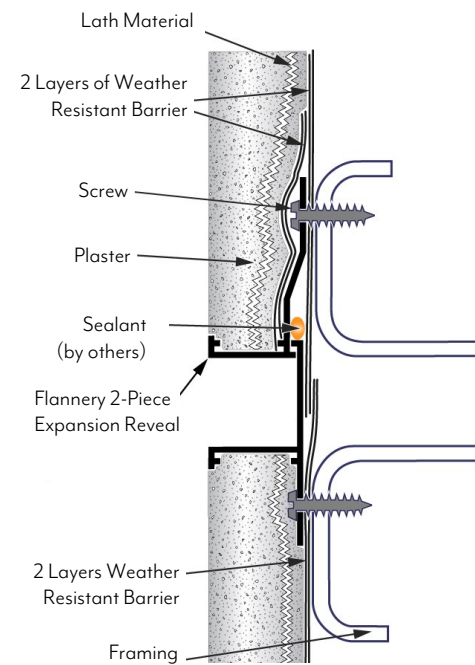

SMOOTH FINISH CHANNEL

Flannery's Smooth Finish Channels create an aesthetic reveal in any stucco wall system. Smooth Finish Channels break up plaster or stucco walls by creating horizontal and vertical reveal lines. Smooth Finish Channels are unique because they do not have the traditional plaster key at the reveal edge. With the plaster key removed, the plasterer can bring the finish coat right up to the reveal edge.

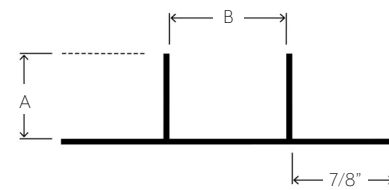

PART NO.	"A" DEPTH	"B" WIDTH
SFC 50-25	1/2"	1/4"
SFC 50-50	1/2"	1/2"
SFC 50-75	1/2"	3/4"
SFC 75-25*	3/4"	1/4"
SFC 75-50	3/4"	1/2"
SFC 75-75	3/4"	3/4"
SFC 75-100*	3/4"	1"
SFC 75-200*	3/4"	2"

*Indicates Modified Part

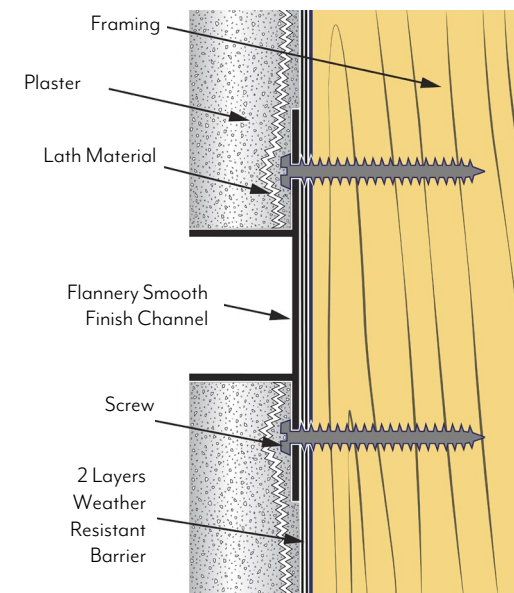

PLASTER CHANNEL SCREED

Flannery's Plaster Channel Screeds create an aesthetic reveal in any stucco wall system. Channel Screeds break up plaster or stucco walls by creating horizontal and vertical reveal lines. Plaster Channel Screeds come in several depths for different stucco thicknesses as well as a number of reveal widths for just the right design look.

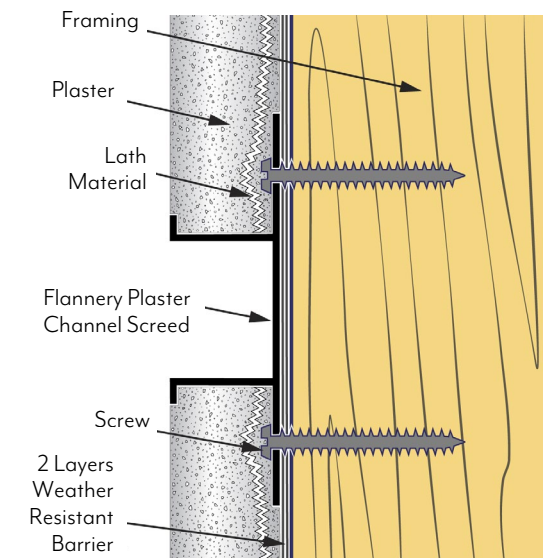
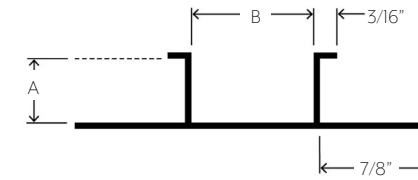

PART NO.	"A" DEPTH	"B" WIDTH
PCS 375-50	3/8"	1/2"
PCS 375-75	3/8"	3/4"
PCS 375-100	3/8"	1"
PCS 375-150	3/8"	1 1/2"
PCS 50-25	1/2"	1/4"
PCS 50-50	1/2"	1/2"
PCS 50-75	1/2"	3/4"
PCS 50-100	1/2"	1"
PCS 50-150	1/2"	1 1/2"
PCS 50-200	1/2"	2"
PCS 50-250	1/2"	2 1/2"
PCS 50-300	1/2"	3"
PCS 50-400	1/2"	4"
PCS 50-600	1/2"	6"
PCS 625-50	5/8"	1/2"
PCS 625-75	5/8"	3/4"
PCS 625-100	5/8"	1"
PCS 625-150	5/8"	1 1/2"
PCS 625-200	5/8"	2"
PCS 625-300	5/8"	3"
PCS 625-400	5/8"	4"
PCS 75-25	3/4"	1/4"
PCS 75-50	3/4"	1/2"
PCS 75-75	3/4"	3/4"
PCS 75-100	3/4"	1"
PCS 75-150	3/4"	1 1/2"
PCS 75-200	3/4"	2"
PCS 75-250	3/4"	2 1/2"
PCS 75-300	3/4"	3"
PCS 75-400	3/4"	4"
PCS 75-600	3/4"	6"
PCS 100-75	1"	3/4"
PCS 100-100	1"	1"

PLASTER CONTROL JOINT

Flannery's Plaster Control Joint creates a 1/4" aesthetic reveal in a typical stucco wall system. It breaks up a plaster wall by creating horizontal and vertical reveal lines. Plaster Control Joints are installed much like Plaster Channel Screeds but have a small 1/4" depth that the Plaster Channel Screed cannot achieve.

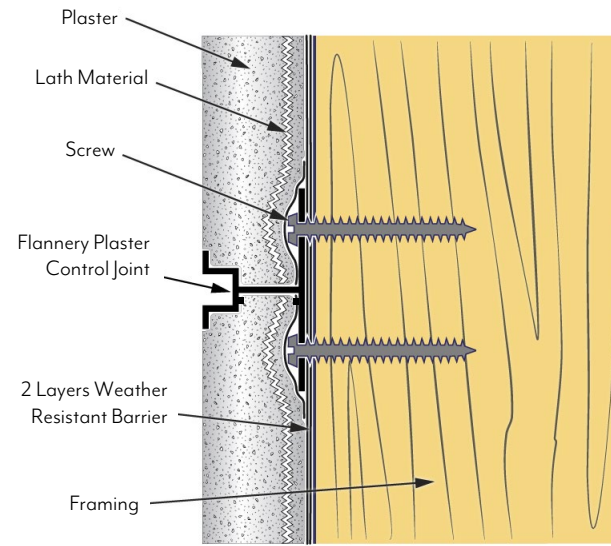
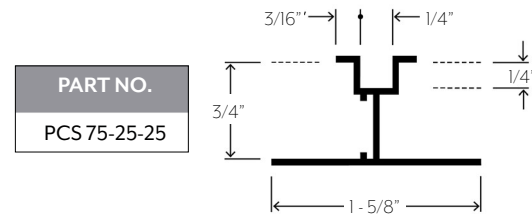

DEEP V-REVEAL

Flannery's Plaster Deep V-Reveal has a unique angled reveal compared to the "square-shaped" Plaster Channel Screed and can elevate any stucco wall system by creating angled horizontal and vertical reveal lines.

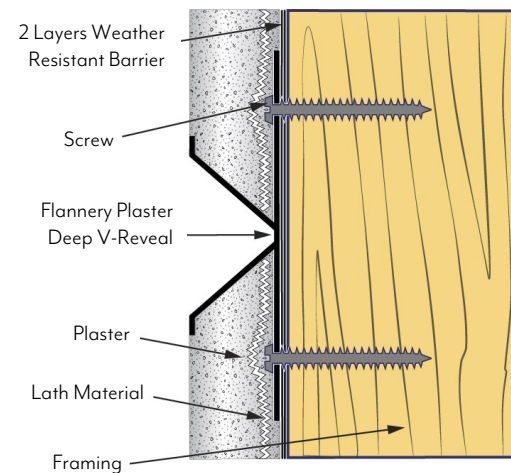
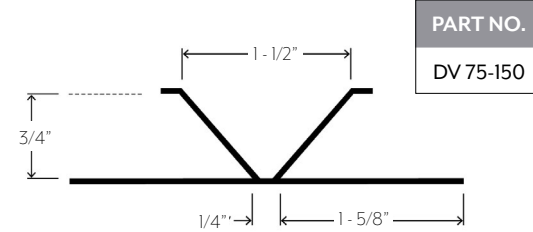

SHORT V-REVEAL

Flannery's Plaster Short V-Reveals are shallow and have a unique angled reveal instead of the "square-shaped" Plaster Control Joint and creates angled horizontal and vertical reveal lines.

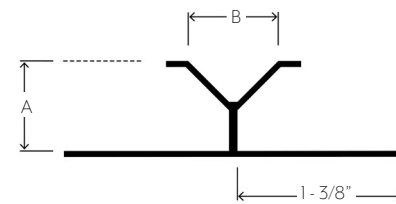

PART NO.	"A" DEPTH	"B" WIDTH
SV 625-75	5/8"	3/4"
SV 75-75	3/4"	3/4"

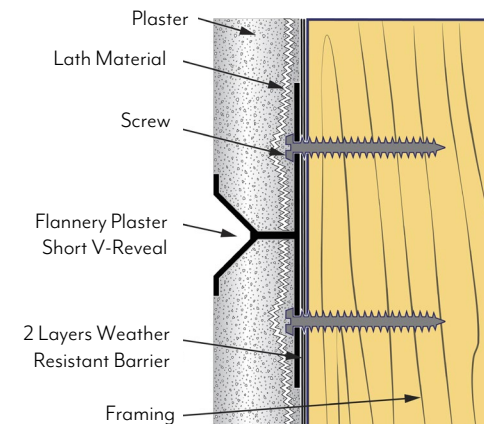

WEEPING REVEAL

Flannery's Weeping Reveals create an aesthetic reveal in any stucco wall system. What makes a weeping reveal unique from the traditional Plaster Channel Screed is that it not only acts as a control joint, but it also acts as a "weeping" reveal. The Weeping Reveal assists in moving water out from behind the plaster layer of a stucco system due to its sloped upper ground leg.

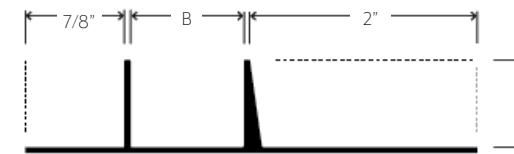

PART NO.	"A" DEPTH	"B" WIDTH
PCSW 50-50 †	1/2"	1/2"
PCSW 50-75 †	1/2"	3/4"
PCSW 50-100 †	1/2"	1"
PCSW 50-150 †	1/2"	1 1/2"
PCSW 50-200 †	1/2"	2"
PCSW 75-50	3/4"	1/2"
PCSW 75-75	3/4"	3/4"
PCSW 75-100	3/4"	1"
PCSW 75-150	3/4"	1 1/2"
PCSW 75-200	3/4"	2"

† indicates limited inventory

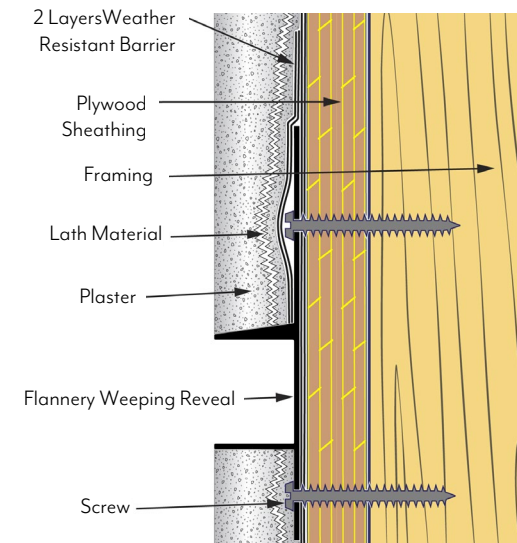

EXPANSION WEEP

Flannery's Expansion Weep acts as a plaster expansion joint designed to allow for the minor movement that may occur within a stucco finish. What makes the Expansion Weep unique is that it not only allows for the minor movement of the stucco finish, but it also acts as a "weeping" reveal. The Expansion Weep assists in moving water out from behind the plaster layer of a stucco system due to its sloped upper ground leg. It comes with a rubber gasket to help join and seal Part A and Part B together. The Expansion Weep creates a 3/4" aesthetic reveal and allows for a 1/4" of movement.

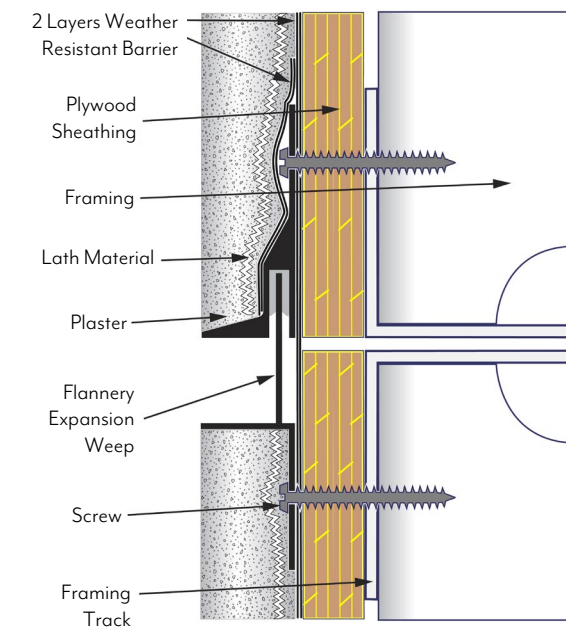
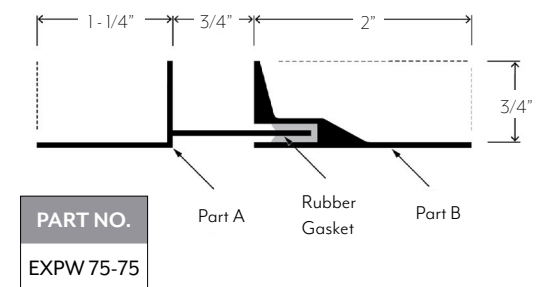

PLASTER F-MOLD

Flannery's Plaster F-Mold creates an aesthetic termination reveal in any stucco wall system. Typically installed where a stucco wall terminates at an opposing wall or dissimilar material, the Plaster F-Mold can act as a stucco stop with a built in reveal.

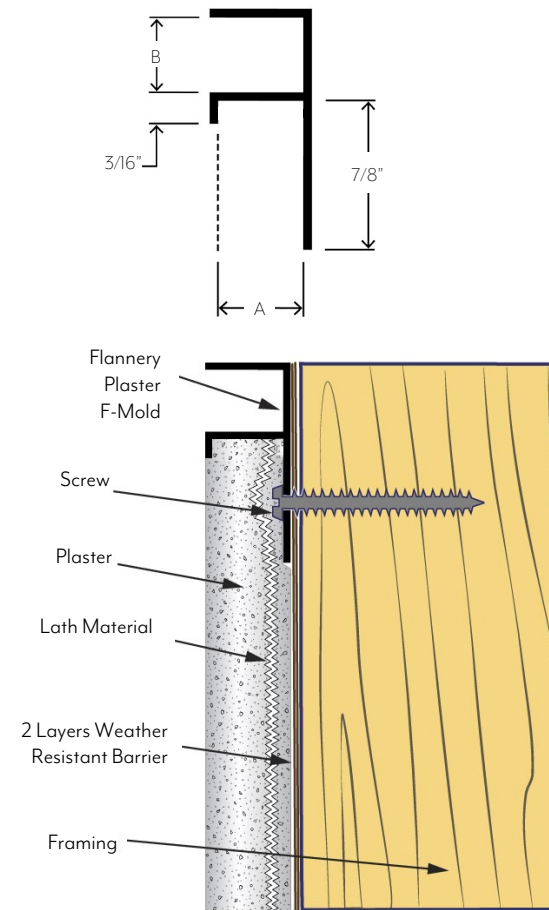

PART NO.	"A" DEPTH	"B" WIDTH
FPM 50-25*	1/2"	1/4"
FPM 50-50	1/2"	1/2"
FPM 50-75	1/2"	3/4"
FPM 50-100*	1/2"	1"
FPM 50-150*	1/2"	1 1/2"
FPM 50-200	1/2"	2"
FPM 50-250*	1/2"	2 1/2"
FPM 50-300*	1/2"	3"
FPM 50-400*	1/2"	4"
FPM 50-600*	1/2"	6"
FPM 625-50	5/8"	1/2"
FPM 625-75	5/8"	3/4"
FPM 625-100	5/8"	1"
FPM 625-150*	5/8"	1 1/2"
FPM 625-200	5/8"	2"
FPM 625-300*	5/8"	3"
FPM 625-400*	5/8"	4"
FPM 75-25	3/4"	1/4"
FPM 75-50	3/4"	1/2"
FPM 75-75	3/4"	3/4"
FPM 75-100	3/4"	1"
FPM 75-150	3/4"	1 1/2"
FPM 75-200	3/4"	2"
FPM 75-250*	3/4"	2 1/2"
FPM 75-300	3/4"	3"
FPM 75-400	3/4"	4"
FPM 75-600*	3/4"	6"

*Indicates Modified Part

SMOOTH FINISH F-MOLD

Flannery's Smooth Finish F-Mold is typically installed where a stucco wall terminates at an opposing wall or dissimilar material. The Smooth Finish F-Mold can act as a stucco stop with a built-in reveal. Smooth Finish F-Molds are unique because they do not have the traditional plaster key at the reveal edge which allow the plasterer to bring the finish coat right up to the reveal edge. **Please note: all sizes are modified.

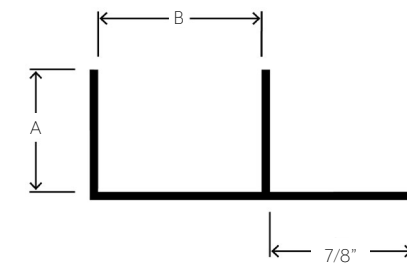

PART NO.	"A" DEPTH	"B" WIDTH
SFF 50-25	1/2"	1/4"
SFF 50-50	1/2"	1/2"
SFF 50-75	1/2"	3/4"
SFF 75-25	3/4"	1/4"
SFF 75-50	3/4"	1/2"
SFF 75-75	3/4"	3/4"
SFF 75-100	3/4"	1"
SFF 75-200	3/4"	2"

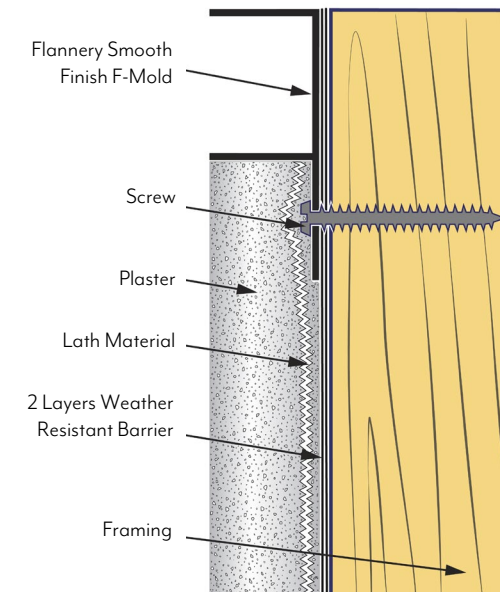

PLASTER J-MOLD

Flannery's Plaster J-Mold is a termination trim that is used to terminate stucco, veneer plaster, drywall or wood panels. Typically installed where a stucco wall terminates at an opposing wall or dissimilar material, the J-Mold can act as a stucco stop.

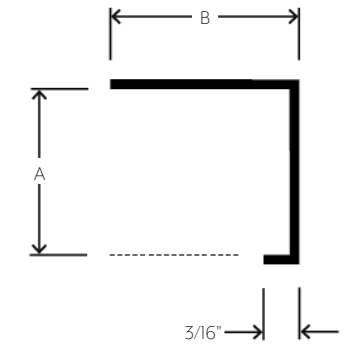

PART NO.	"A" DEPTH	"B" WIDTH
JPM 375	3/8"	1"
JPM 50	1/2"	1"
JPM 75	3/4"	1"
JPM 850-100	7/8"	1"
JPM 850-200	7/8"	2"

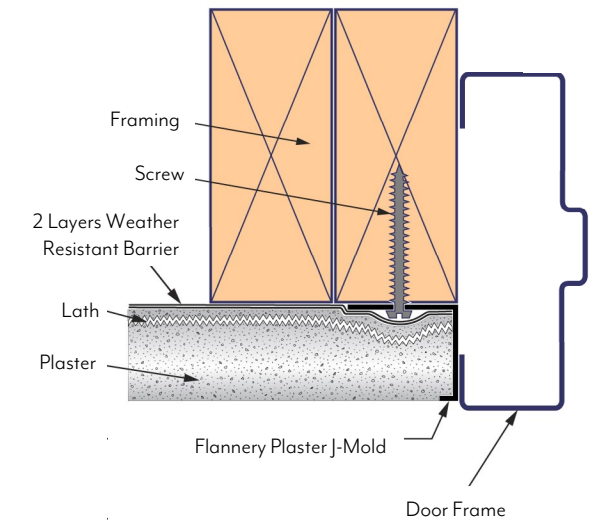

PLASTER T-MOLD

Flannery's T-Mold creates an aesthetic termination trim with a reveal wherever you wish to terminate stucco. The T-Mold can act as a stucco stop with a built-in reveal and is available in many custom depths and reveal widths.

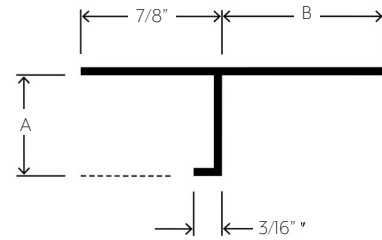
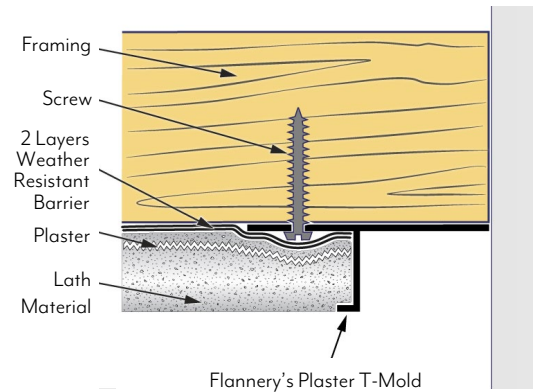

PART NO.	"A" DEPTH	"B" WIDTH
TPM 50-50*	1/2"	1/2"
TPM 50-75*	1/2"	3/4"
TPM 625-50*	5/8"	1/2"
TPM 625-75	5/8"	3/4"
TPM 75-50*	3/4"	1/2"
TPM 75-75	3/4"	3/4"
TPM 75-100*	3/4"	1"
TPM 75-150	3/4"	1 1/2"

*Indicates Modified Part

SOFFIT W-MOLD

Flannery's Soffit W-Molds create a transition edge where a stucco soffit meets a dissimilar wall or material. They are typically set at corner joint where a soffit ceiling terminates at a vertical wall.

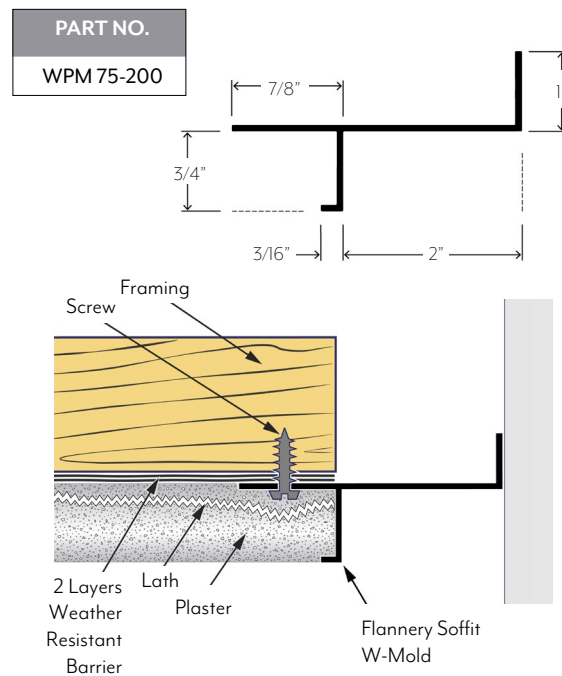

FASCIA CORNER MOLD

Flannery's Fascia Corner Molds create a transition corner where a stucco fascia edge meets a stucco soffit and are typically set at the corner joint where a fascia terminates and a soffit return begins. The horizontal fascia leg acts as a stucco stop, while the opposite flange acts as a soffit trim. Flannery's Fascia Corner Molds can also be used where an interior stucco or veneer plaster fascia terminates at an acoustical ceiling.

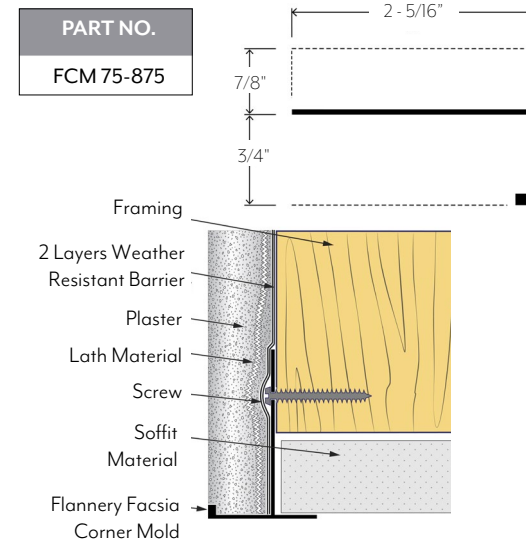

DRIP SCREED

Flannery's Drip Screeds create a drip edge for moisture to "drip" off stucco fascia edges preventing it from running back across a soffit. Drip Screeds are typically set at the corner joint where a fascia meets a soffit. They come with a fascia leg that acts as a stucco stop and a reveal which acts as a drip edge.

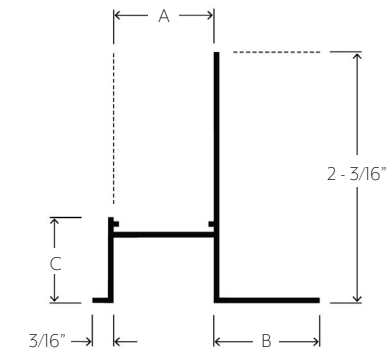

PART NO.	"A" WIDTH	"B" WIDTH	"C" DEPTH
DS 875-875	7/8"	7/8"	3/4"
DS 75-50	3/4"	1/2"	1/2"
DS 75-75	3/4"	3/4"	3/4"
DS 50-100	1/2"	1"	3/4"
DS 200-875	2"	7/8"	3/4"

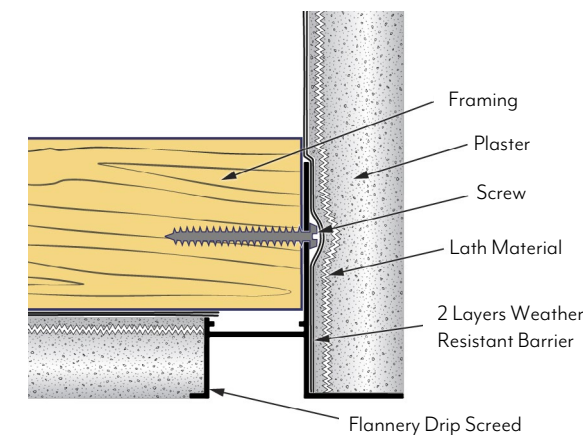

2-PIECE DRIP SCREED

Flannery's 2-pc. Drip Screeds create a drip edge for moisture to "drip" off stucco fascia edges preventing it from running back across a soffit. Drip Screeds are typically set at the corner joint where fascias meet a soffit. 2-Pc. Drip Screeds come in various reveal depths and widths to cater to a variety of stucco soffit thicknesses.

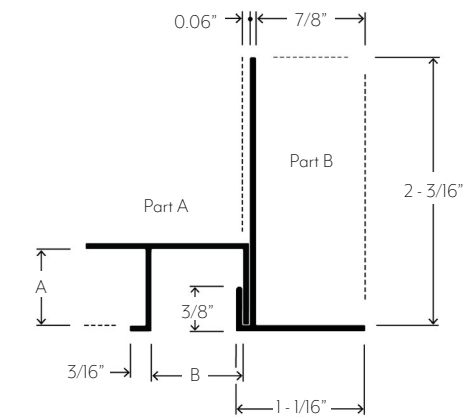

PART NO.	"A" DEPTH	"B" WIDTH
DS 50-50-2pc	1/2"	1/2"
DS 50-75-2pc	1/2"	3/4"
DS 625-50-2pc	5/8"	1/2"
DS 625-75-2pc	5/8"	3/4"
DS 75-50-2pc	3/4"	1/2"
DS 75-75-2pc	3/4"	3/4"
DS 75-100-2pc	3/4"	1"
DS 75-150-2pc	3/4"	1 1/2"
DS 75-200-2pc	3/4"	2"
DS 75-300-2pc	3/4"	3"
DS 75-400-2pc	3/4"	4"

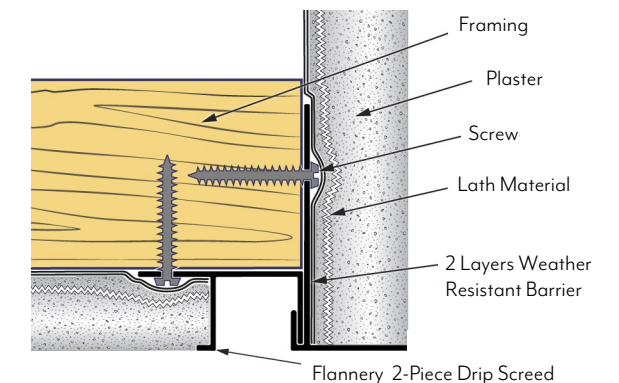

PLASTER WINDOW RETURN

Flannery's Plaster Window Return creates an aesthetic termination point where a stucco wall terminates at a recessed window frame.

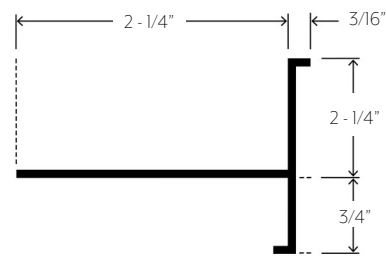

PART NO.
WRPG 75-225

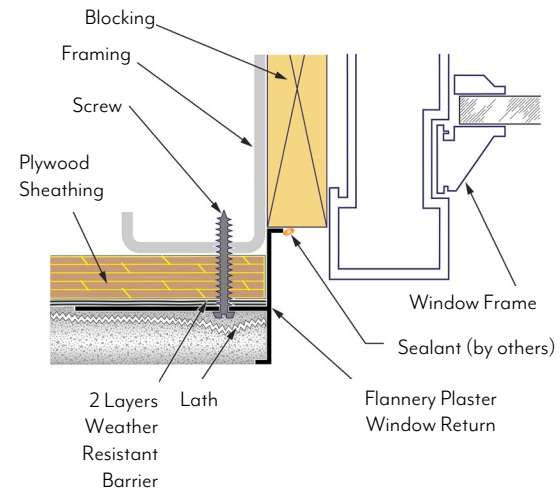

SELF-WEEPING WINDOW DRIP

Flannery's Self-Weeping Window Drip acts as a window drip that prevents moisture from entering the head assembly of any window opening in a stucco wall system. The Self-Weeping Window Drip comes with an offset attachment flange to allow for window head movement.

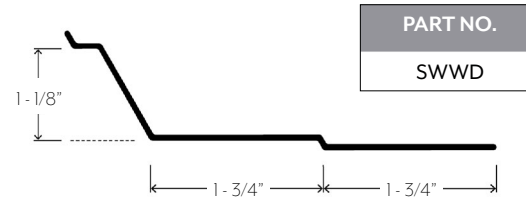

PART NO.
SWWD

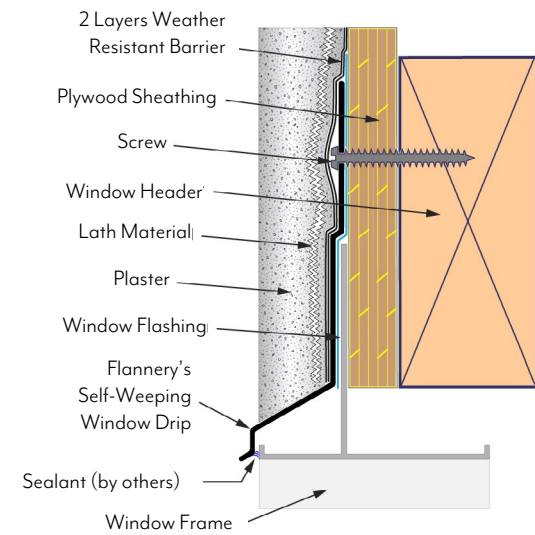

ALUMINUM WEEP SCREED

Flannery's Aluminum Weep Screed is a foundation weep screed with the benefit of a 3/2" code leg. It performs as a stucco stop typically installed at the base of a stucco wall system. Its main purpose is to alleviate moisture from behind the plaster cement layer of a stucco wall system.

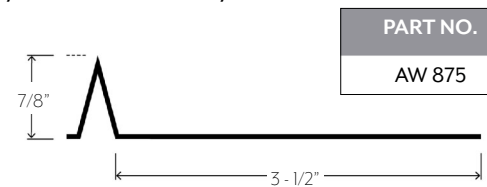

PART NO.
AW 875

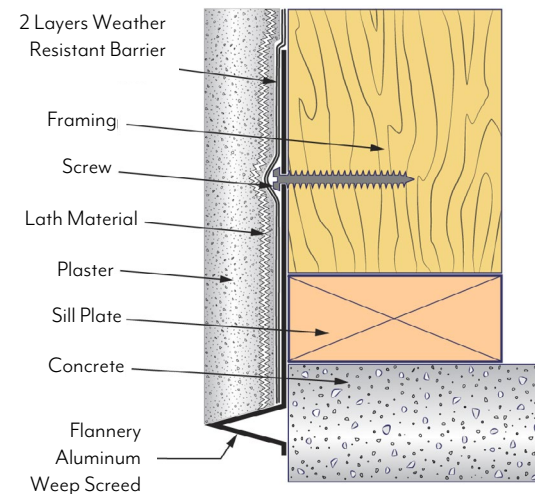

PLASTER PARAPET CAP

Flannery's Plaster Parapet Cap is a stucco termination trim that is used at the top of exterior walls without an overhang or soffit and has a return leg that can be integrated into a fabricated sheet metal parapet cap to finish off the building's parapet and prevent moisture from getting behind the fascia wall and roofing materials. Flannery can also manufacture custom sheet metal return flashings if needed.

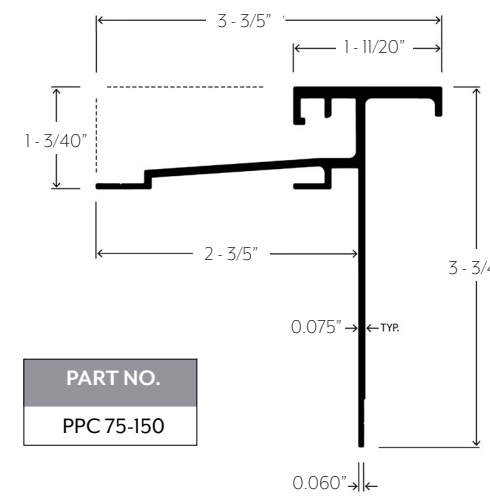

PART NO.
PPC 75-150

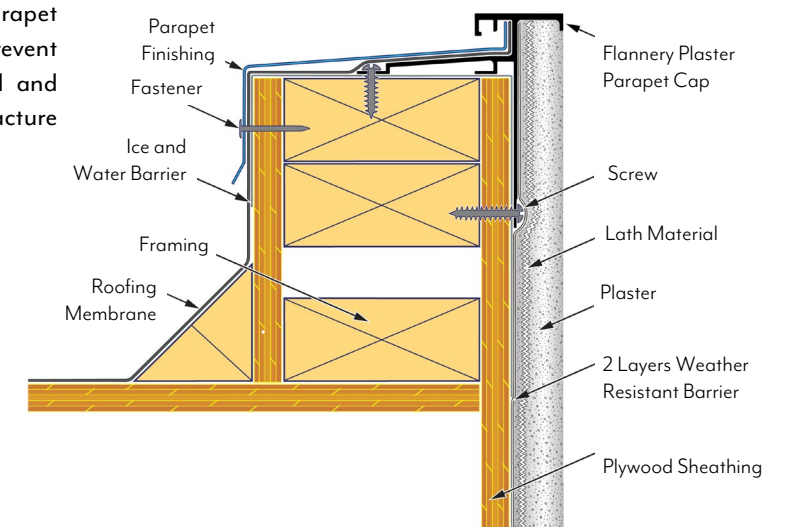

PLASTER X-MOLD

Flannery's Plaster X-Mold is an outside corner trim that creates an aesthetic reveal at a 90° outside corner. Plaster X-Molds are straighter and cleaner corner trims compared to standard welded wire corners.

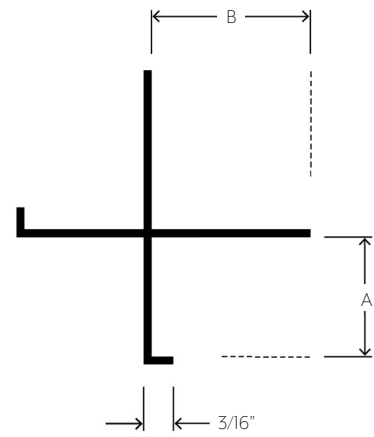

PART NO.	"A" DEPTH	"B" WIDTH
XPM 50-50	½"	¾"
XPM 625-625	⅝"	¾"
XPM 75-75	¾"	1"

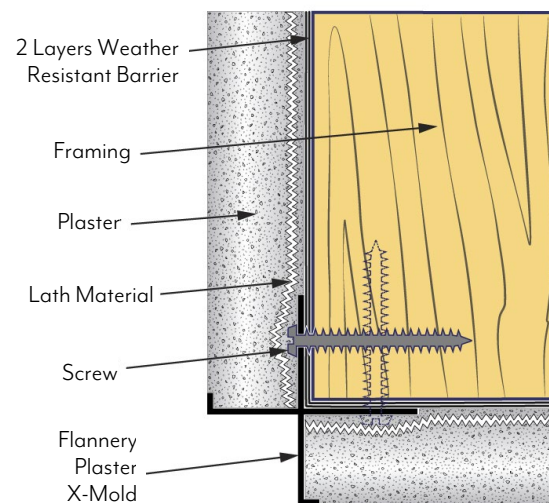

PLASTER CORNER MOLD

Flannery's Plaster Corner Mold is an outside corner trim that creates a sharp 90° aluminum corner. Plaster Corner Molds are straighter and cleaner corner trims compared to a standard welded wire corner.

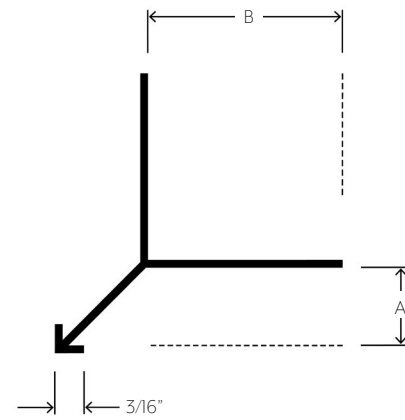

PART NO.	"A" DEPTH	"B" WIDTH
PCM 50	½"	1 ¼"
PCM 75	¾"	1 ¼"

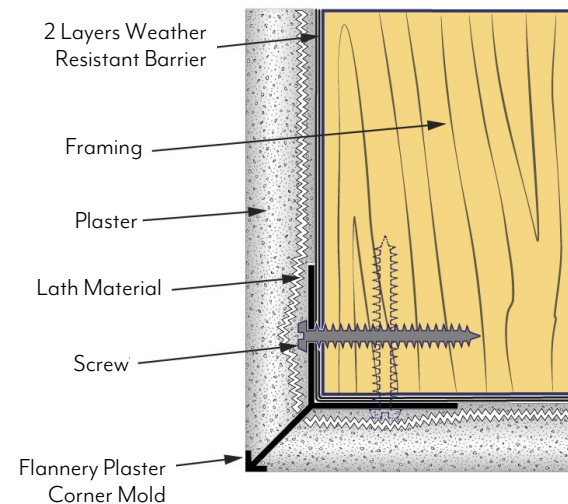

WELDED INTERSECTIONS AND CORNERS

Flannery's prefabricated factory intersections and corners for exterior trims are manufactured with the same or different moldings. They are used to complete intricate building designs that utilize intersecting lines (both vertical and horizontal) around interior or exterior walls. The intersections and corners are mitered and then heli-arc welded at the installation flanges. A seal is then applied to the back of the intersecting butt joints. The standard intersection or corner comes with 6" legs from the center point of the reveal. Custom leg lengths are also available. All installation flanges must be covered with lath and all butt joints must be sealed. Please note that Flannery's Plaster F-Mold and Channel Screed are not the only Plaster & Stucco trims that can be welded and fabricated. Please take a look at all the individual product pages on our website to see our fabrication capabilities.

INTERSECTIONS FOR FPM

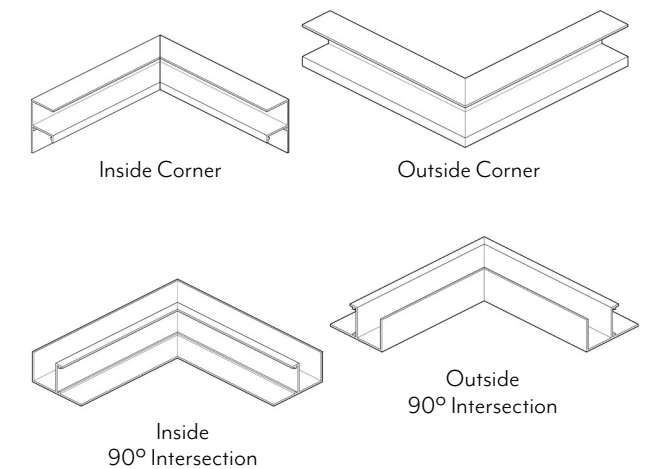

INTERSECTIONS FOR PCS

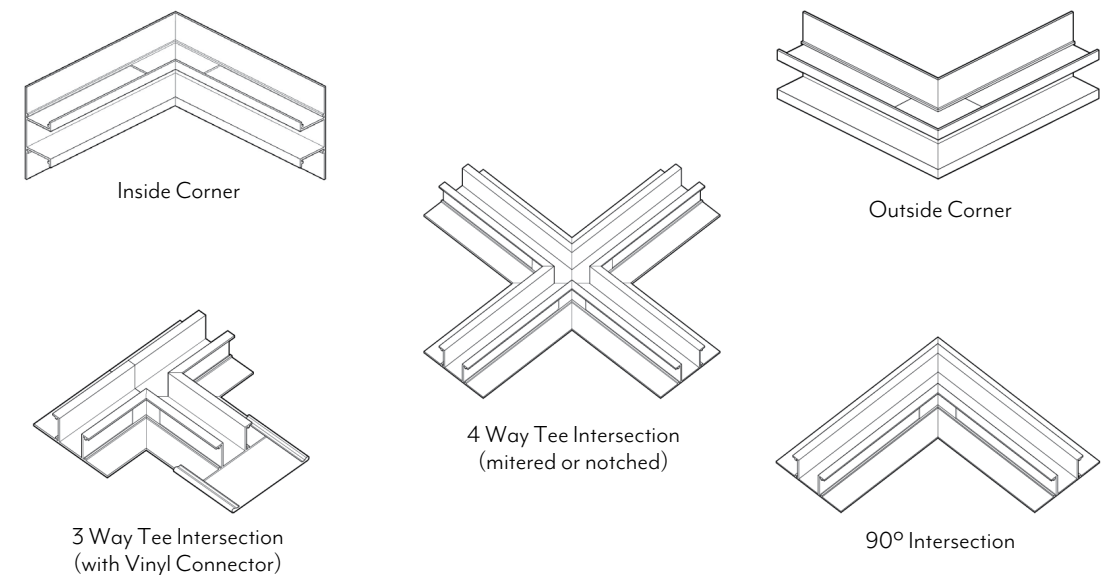

FACTORY RADIUS

VARIETY OF DESIGN OPTIONS

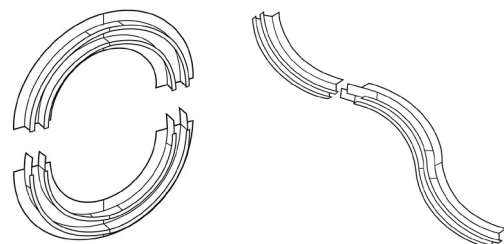

Radius Shapes are factory curved or bent pieces of material that are necessary when a Flannery trim runs along a “curved” or “radiused” plane. Radiused material is bent to a project’s dimensional requirements and is considered a custom product.

Here are some things you should consider when ordering radiused material:

- Radius Shapes are formed from 10’ pieces of material. Usually, only 9’ of that material will be usable for installation due to machining marks.

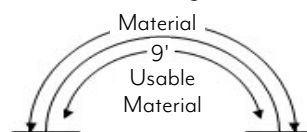

- Radius Order Forms can be downloaded at flannerytrim.com under the specific product page of the trim being bent.

- Flannery accepts a template if a radius is complex or undefined by the architectural plans.

When placing an order for radius with Flannery, please indicate the following:

1. Product Type (product code and finish required).
2. Direction of Bend (Inside Curve, Outside Curve, Arch, or Reverse Arch).
3. Size of Radius (in inches or feet).
4. Point of Measurement (the point on the trim where the radius is measured to).
5. Quantity of Pieces Required.

Please note that products beyond what is displayed on this page can be radiused. Please take a look at all the individual product pages on our website to see a specific trim’s capabilities.

RADIUS FOR PCS

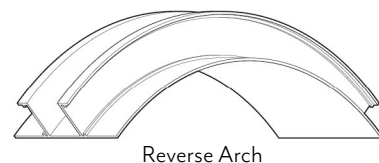
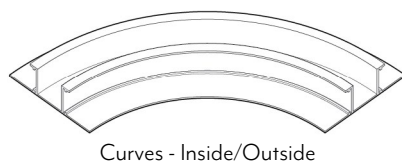
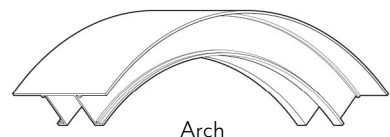

RADIUS FOR FPM

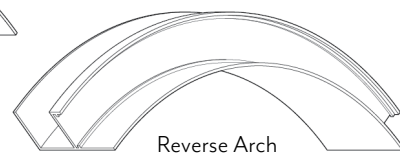
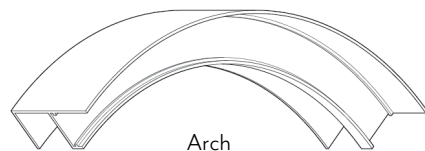
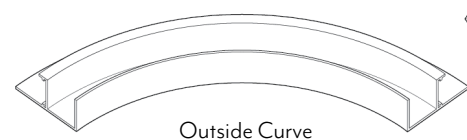

SPECIFICATIONS FOR PLASTER & STUCCO TRIM

INSTALLATION INSTRUCTIONS FOR EXTERIOR REVEAL MOLDINGS INSTALLED VERTICALLY

1. Building Paper must be placed behind all moldings and have a shiplap of 6”.
2. Attach moldings 16” on center to framing using approved fastening methods. Butt joints must be cut accurately and sealed.
3. Install lath over installation flanges of all moldings.
4. Mask all reveals prior to plastering. Use cloth or vinyl tape specifically manufactured for masking anodized aluminum moldings. For painted moldings, use vinyl tape.

INSTALLATION INSTRUCTIONS FOR EXTERIOR REVEAL MOLDINGS INSTALLED HORIZONTALLY

1. Building paper must be placed behind all moldings and have a shiplap of at least 2”.
2. Attach moldings 16” or 24” on center to framing using approved fastening methods. Butt joints must be cut accurately and sealed.
3. Install lath over installation flanges of all moldings.
4. Mask all reveals prior to plastering. Use cloth or vinyl tape specifically manufactured for masking anodized aluminum moldings. For painted moldings, use vinyl tape.

INSTALLATION INSTRUCTIONS FOR EXTERIOR REVEAL MOLDINGS OVER METAL LATH

1. Molding selection must be in accordance with the proper plaster thickness specified.
2. Moldings must be tied to the lath with tie wire, thus protecting the waterproof membrane. Flannery offers factory punched stucco “key” holes along the reveal attachment flanges to assist in tying the trim to the metal lath or wire. Butt joints must be cut accurately and sealed.

3. All installation flanges of the moldings must be covered with lath.
4. Please note that the Uniform Building Code requires two layers of grade “D” paper when applied over wood-based sheathing.
5. Mask all reveals prior to plastering. Use cloth or vinyl tape specifically manufactured for masking anodized aluminum moldings. For painted moldings, use vinyl tape.

INSTALLATION INSTRUCTIONS FOR WEEP, DOOR & WINDOW OR SOFFIT DRIP SCREEDS

Weep Screeds, Door & Window Drips or Soffit Drip Screeds should be installed per the architect or building engineer’s installation instructions.

Flannery recommends the following steps to help assist the installer in maximizing these trims’ main purpose, which is water management:

1. Before Flannery’s weeping trims are installed, required waterproofing for door and window openings should be inspected and evaluated for proper installation.
2. All Weep or Drip Screeds should be attached horizontally 16” or 24” on center to framing using approved fastening methods. Butt joints must be cut accurately and sealed.
3. Building paper or the weather resistant barrier should then be installed over the corresponding attachment flanges to prevent moisture from getting in behind the trim.
4. Install lath over the corresponding attachment flanges of the molding.
5. If the trim has a reveal, use cloth or vinyl tape specifically manufactured for masking anodized aluminum moldings prior to plastering. For painted moldings, use vinyl tape.

PLASTER & STUCCO TRIM ACCESSORIES

ALIGNMENT SPLICES

Many of Flannery's Plaster Trims are available with our exclusive Aluminum Alignment Splices. Flannery offers our Straight Splices free of charge and our Special Corner or 90° Intersection splices for a small charge. Straight Splices assist the installer in aligning and joining aluminum trims together along a straight plane. Installers who cut their own miters in the field can use our Special Corner and 90° Intersection Splices to bring the cut pieces together for a tight and clean butt/miter joint.

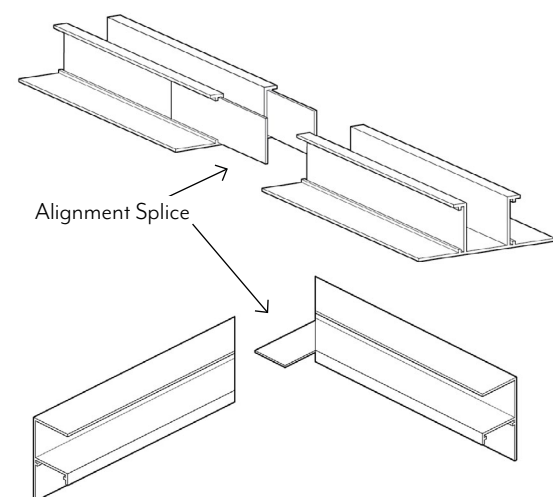

VINYL CONNECTOR CLIPS

Flannery provides Vinyl Connector Clips for many of our Plaster Channel Screeds to assist the installer in lining up and sealing butt joints. Sealant is required at all butt joints and Flannery's Vinyl Connector Clips can be utilized as a bed for the sealant to be applied between two pieces of trim. Vinyl Connector Clips for Flannery's Plaster Channel Screeds are provided free of charge.

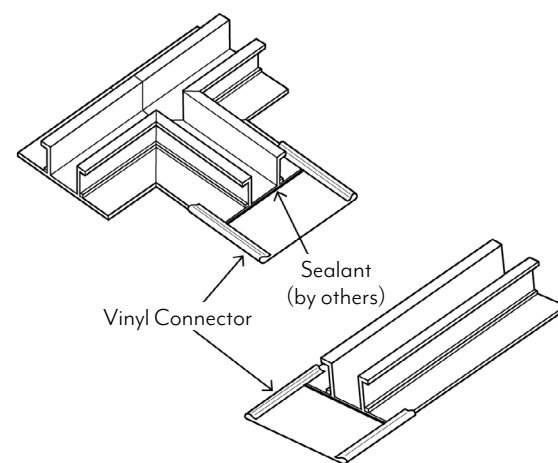

CHANNEL END CAPS

Flannery offers Channel End Caps for all sizes of the Plaster Channel Screeds and other reveals. End Caps create a termination point for any reveal where the channel may terminate against a dissimilar material such as a door or window frame. They can also be used when a channel terminates in the middle of a plaster wall.

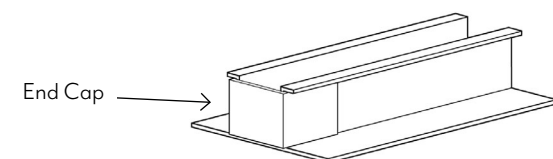

SOFFIT VENTILATION TRIM SHAPEFINDER

Exterior soffit ventilation is a must for most exterior wall systems. The following pages highlight the many different aluminum trims that Flannery can ventilate to allow for the proper movement of air into an exterior soffit or overhang. Flannery's continuous vents come with a rigid and uniform "slot" pattern to enhance the high-visibility nature of a building's entrance or overhead ceiling area. In addition to being aesthetically pleasing, our Soffit Ventilation serves the practical purpose of keeping framing members dry and cool to prevent rot and deterioration in an overhead soffit cavity.

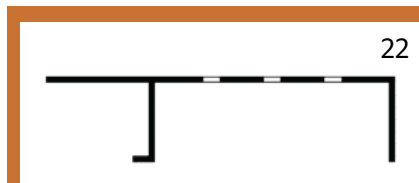

PLASTER F-MOLD VENT



CHANNEL SCREED VENT

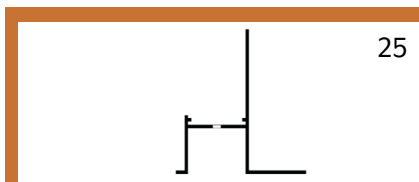

DRIP SCREED VENT



SMOOTH FINISH EIFS VENT

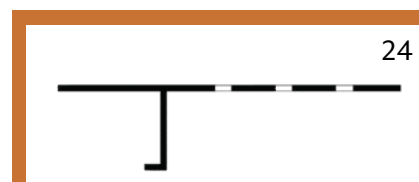

PLASTER T-MOLD VENT

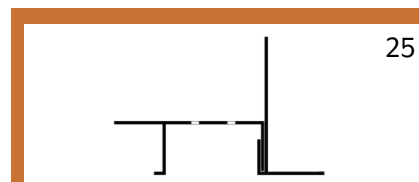

2-PIECE DRIP SCREED VENT

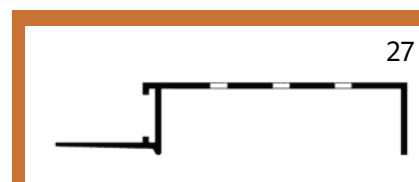

DIRECT APP. EIFS F-MOLD VENT

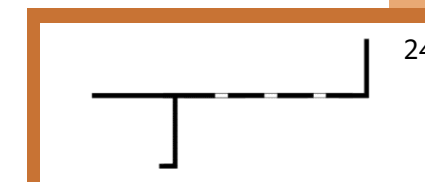

SOFFIT W-MOLD

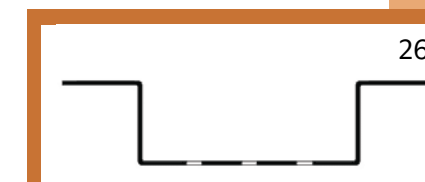

HAT CHANNEL VENT

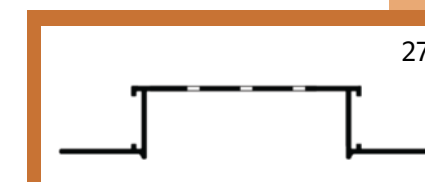

DIRECT APP. EIFS VENT

PLASTER F-MOLD VENT

Flannery's Plaster F-Mold Vent creates a soffit ventilation strip where a plaster soffit meets a dissimilar material or wall. Flannery's Continuous Soffit Vents come in a number of depths for different soffit material thicknesses as well as a number of reveal widths for just the right amount of ventilation.

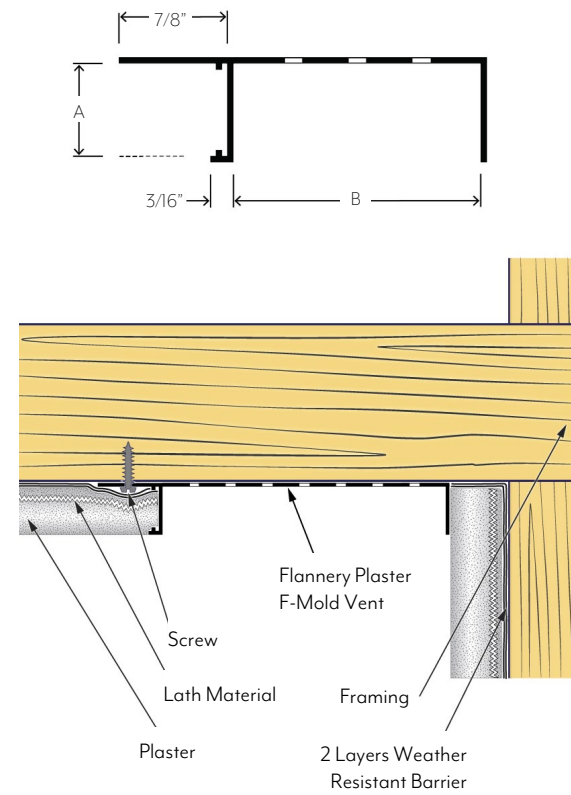

PART NO.	"A" DEPTH	"B" WIDTH	VENT SLOTS PER ROW
FPM 50-V-50	½"	½"	1
FPM 50-V-75	½"	¾"	1
FPM 50-V-100*	½"	1"	1
FPM 50-V-150*	½"	1½"	2
FPM 50-V-200	½"	2"	3
FPM 50-V-250*	½"	2½"	3
FPM 50-V-300*	½"	3"	5
FPM 50-V-400*	½"	4"	7
FPM 50-V-600*	½"	6"	9
FPM 625-V-50	⅝"	½"	1
FPM 625-V-75	⅝"	¾"	1
FPM 625-V-100	⅝"	1"	1
FPM 625-V-150*	⅝"	1½"	2
FPM 625-V-200	⅝"	2"	3
FPM 625-V-300*	⅝"	3"	5
FPM 625-V-400*	⅝"	4"	7
FPM 75-V-50	¾"	½"	1
FPM 75-V-75	¾"	¾"	1
FPM 75-V-100	¾"	1"	1
FPM 75-V-150	¾"	1½"	2
FPM 75-V-200	¾"	2"	3
FPM 75-V-250*	¾"	2½"	3
FPM 75-V-300	¾"	3"	5
FPM 75-V-400	¾"	4"	7
FPM 75-V-600*	¾"	6"	9

*Indicates Modified Part

CHANNEL SCREED VENT

Flannery's Channel Screed Vent creates an aesthetic ventilation strip in a soffit area. Flannery's Channel Screed Vents come in a number of depths for different soffit material thicknesses as well as a number of reveal widths for just the right amount of ventilation.

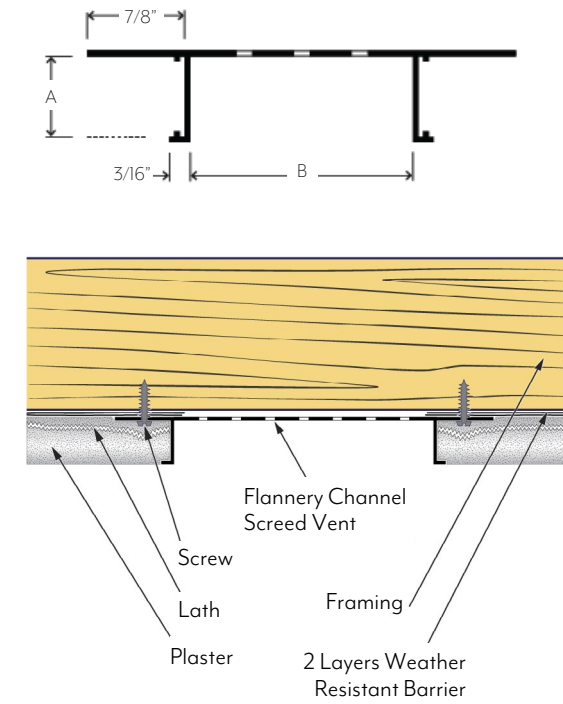

PART NO.	"A" DEPTH	"B" WIDTH	VENT SLOTS PER ROW
PCS 375-V-50	⅜"	½"	1
PCS 375-V-75	⅜"	¾"	1
PCS 375-V-100	⅜"	1"	1
PCS 375-V-150	⅜"	1½"	2
PCS 50-V-50	½"	½"	1
PCS 50-V-75	½"	¾"	1
PCS 50-V-100	½"	1"	1
PCS 50-V-150	½"	1½"	2
PCS 50-V-200	½"	2"	3
PCS 50-V-250	½"	2½"	3
PCS 50-V-300	½"	3"	5
PCS 50-V-400	½"	4"	7
PCS 50-V-600	½"	6"	9
PCS 625-V-50	⅝"	½"	1
PCS 625-V-75	⅝"	¾"	1
PCS 625-V-100	⅝"	1"	1
PCS 625-V-150	⅝"	1½"	2
PCS 625-V-200	⅝"	2"	3
PCS 625-V-300	⅝"	3"	5
PCS 625-V-400	⅝"	4"	7
PCS 75-V-75	¾"	¾"	1
PCS 75-V-100	¾"	1"	1
PCS 75-V-150	¾"	1½"	2
PCS 75-V-200	¾"	2"	3
PCS 75-V-250	¾"	2½"	3
PCS 75-V-300	¾"	3"	5
PCS 75-V-400	¾"	4"	7
PCS 75-V-600	¾"	6"	9

PLASTER T-MOLD VENT

Flannery's Plaster T-Mold Vent creates a ventilation strip where a plaster soffit meets a dissimilar material or wall. Flannery's Plaster T-Mold Vents come in a number of depths for different soffit material thicknesses as well as a number of reveal widths for just the right amount of ventilation and custom sizes are also available.

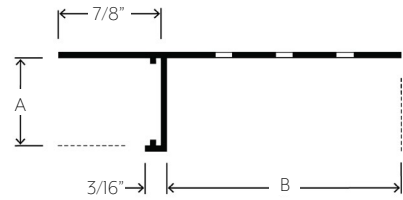

PART NO.	"A" DEPTH	"B" WIDTH	VENT SLOTS PER ROW
TPM 50-50*	1/2"	1/2"	1
TPM 50-75*	1/2"	3/4"	1
TPM 625-50*	5/8"	1/2"	1
TPM 625-75	5/8"	3/4"	1
TPM 75-50*	3/4"	1/2"	1
TPM 75-75	3/4"	3/4"	1
TPM 75-150	3/4"	1 1/2"	2

*Indicates Modified Part

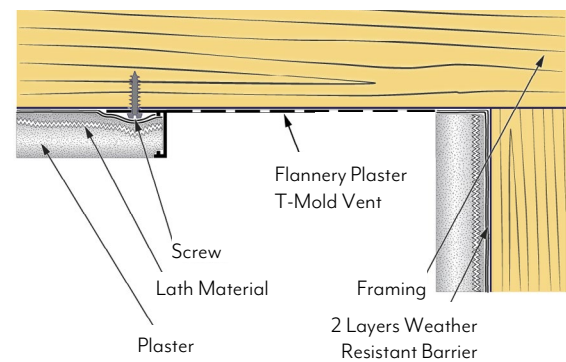

SOFFIT W-MOLD VENT

Flannery's Soffit W-Mold vent creates a ventilation strip where a stucco soffit meets a dissimilar wall or material and is typically set at a corner joint where a soffit return meets a vertical wall.

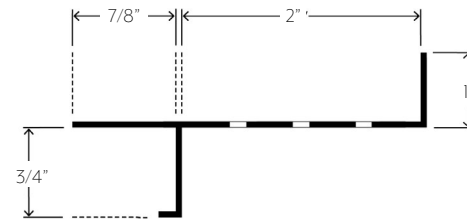

PART NO.
WPM 75-V-200

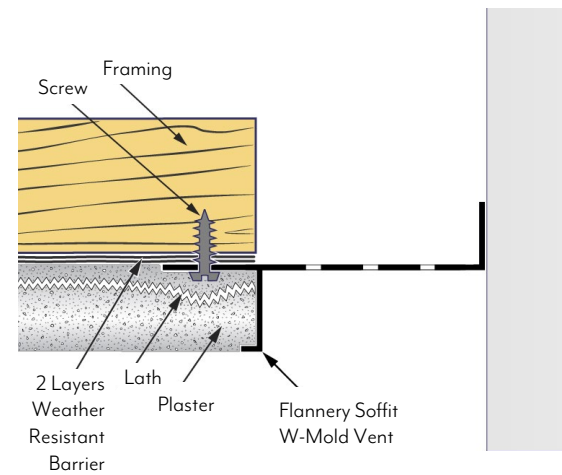

DRIP SCREED VENT

Flannery's Drip Screed Vent is a soffit vent that creates a drip edge for moisture to "drip" off of stucco fascia edge preventing moisture from running back across a soffit. Drip Screed Vents should not be installed where a framing member runs parallel to the vent strip since it may prevent the movement of air.

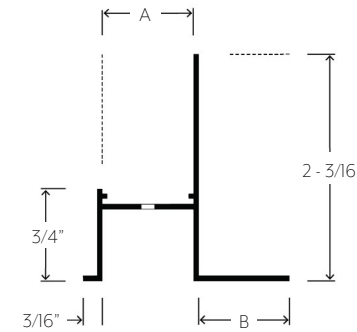

PART NO.	"A" WIDTH	"B" WIDTH	VENT SLOTS PER ROW
DS 875-V-875	7/8"	7/8"	1
DS 75-V-75	3/4"	3/4"	1
DS 200-V-875	2"	7/8"	3

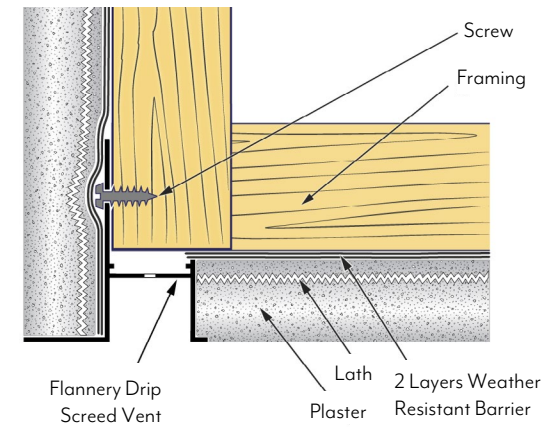

2-PIECE DRIP SCREED VENT

Flannery's 2-Piece Drip Screed Vent creates an edge for moisture to "drip" off of fascia edges preventing it from running back across a soffit. These should not be installed where a framing member runs parallel to the vent strip since it prevent the movement. Custom sizes are available.

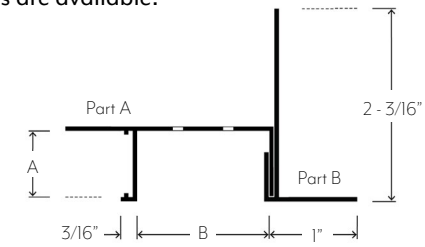

PART NO.	"A" DEPTH	"B" WIDTH	VENT SLOTS PER ROW
DS 50-V-50-2pc	1/2"	1/2"	1
DS 50-V-75-2pc	1/2"	3/4"	1
DS 50-V-200-2pc	1/2"	2"	3
DS 625-V-50-2pc	5/8"	1/2"	1
DS 625-V-75-2pc	5/8"	3/4"	1
DS 625-V-100-2pc	5/8"	1"	1
DS 75-V-50-2pc	3/4"	1/2"	1
DS 75-V-75-2pc	3/4"	3/4"	1
DS 75-V-100-2pc	3/4"	1"	1
DS 75-V-150-2pc	3/4"	1 1/2"	2
DS 75-V-200-2pc	3/4"	2"	3
DS 75-V-300-2pc	3/4"	3"	5
DS 75-V-400-2pc	3/4"	4"	7

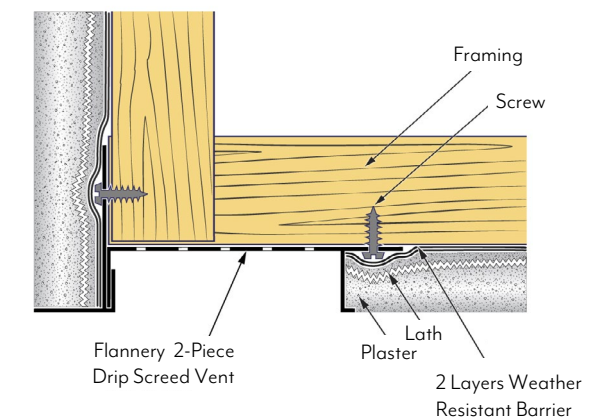

HAT CHANNEL VENT

Flannery's Hat Channel Vent creates a soffit ventilation strip that is flush with a desired soffit material and are typically fastened to the framing prior to the soffit material being installed. This is a brake-formed product that is available in .040" thick Aluminum.

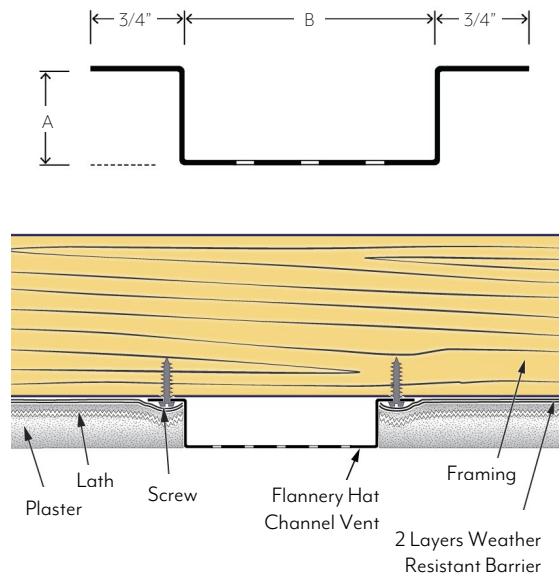

PART NO.	"A" DEPTH	"B" WIDTH	VENT SLOTS PER ROW
HCV 50-V-150	1/2"	1 1/2"	2
HCV 50-V-200	1/2"	2"	3
HCV 50-V-300	1/2"	3"	5
HCV 50-V-400	1/2"	4"	7
HCV 625-V-150	5/8"	1 1/2"	2
HCV 625-V-200	5/8"	2"	3
HCV 625-V-300	5/8"	3"	5
HCV 625-V-400	5/8"	4"	7
HCV 75-V-150	3/4"	1 1/2"	2
HCV 75-V-200	3/4"	2"	3
HCV 75-V-300	3/4"	3"	5
HCV 75-V-400	3/4"	4"	7
HCV 875-V-150	7/8"	1 1/2"	2
HCV 875-V-200	7/8"	2"	3
HCV 875-V-300	7/8"	3"	5
HCV 100-V-150	1"	1 1/2"	2
HCV 100-V-200	1"	2"	3

SMOOTH FINISH EIFS VENT

Flannery's Smooth Finish EIFS Vents are soffit ventilated trims that can be inserted into an exterior insulation and finishing system (EIFS) soffit. Smooth Finish EIFS Vents are installed after the EIFS substrate and final finish coat have been applied to the system. This eases the installation process and reduces the amount of labor required to install a soffit vent.

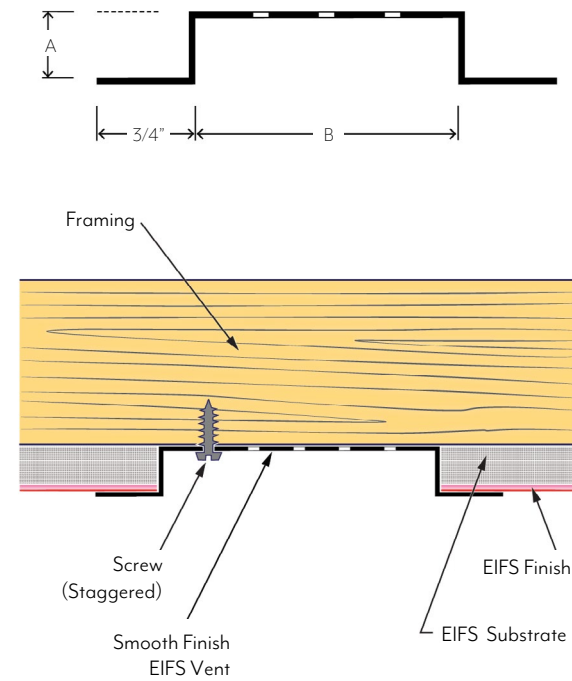

PART NO.	"A" DEPTH	"B" WIDTH	VENT SLOTS PER ROW
SFEV 50-V-200	1/2"	2"	3
SFEV 50-V-300	1/2"	3"	5
SFEV 50-V-400	1/2"	4"	7
SFEV 75-V-400	3/4"	4"	7

DIRECT EIFS F-MOLD VENT

Flannery's Direct Application EIFS F-Mold Vents are soffit ventilated trims that can be inserted into an exterior insulation and finishing system (EIFS) soffit where the system requires a vent along a dissimilar wall or material.

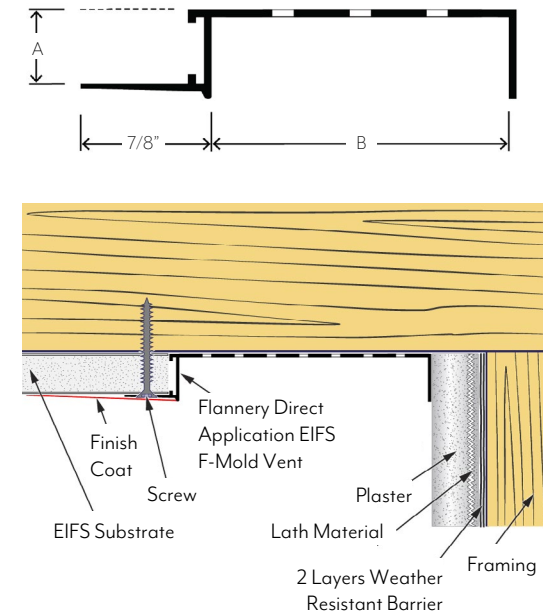

PART NO.	"A" DEPTH	"B" WIDTH	VENT SLOTS PER ROW
DWRF 50-V-50	1/2"	1/2"	1
DWRF 50-V-75	1/2"	3/4"	1
DWRF 50-V-100	1/2"	1"	1
DWRF 50-V-150	1/2"	1 1/2"	2
DWRF 50-V-200	1/2"	2"	3
DWRF 50-V-300*	1/2"	3"	5
DWRF 50-V-600*	1/2"	6"	9
DWRF 625-V-50	5/8"	1/2"	1
DWRF 625-V-75	5/8"	3/4"	1
DWRF 625-V-100	5/8"	1"	1
DWRF 625-V-150	5/8"	1 1/2"	2
DWRF 625-V-200	5/8"	2"	3
DWRF 625-V-300*	5/8"	3"	5
DWRF 625-V-400*	5/8"	4"	7

*Indicates Modified Part

DIRECT EIFS VENT

Flannery's Direct Application EIFS Vents are soffit ventilated trims that can be inserted into an exterior insulation and finishing system (EIFS) soffit. With their beveled and thinning attachment flanges, Direct Application EIFS Vents can be installed over the EIFS substrate before the final finish is applied.

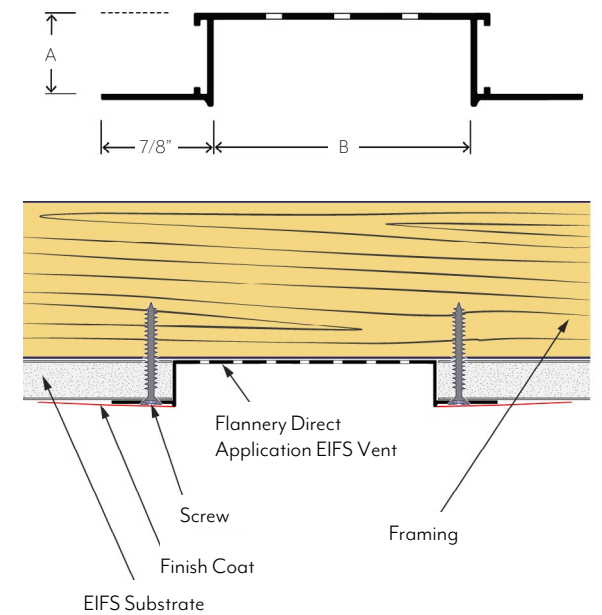

PART NO.	"A" DEPTH	"B" WIDTH	VENT SLOTS PER ROW
DWR 50-V-50	1/2"	1/2"	1
DWR 50-V-75	1/2"	3/4"	1
DWR 50-V-100	1/2"	1"	1
DWR 50-V-150	1/2"	1 1/2"	2
DWR 50-V-200	1/2"	2"	3
DWR 50-V-300	1/2"	3"	5
DWR 50-V-600	1/2"	6"	9
DWR 625-V-50	5/8"	1/2"	1
DWR 625-V-75	5/8"	3/4"	1
DWR 625-V-100	5/8"	1"	1
DWR 625-V-150	5/8"	1 1/2"	2
DWR 625-V-200	5/8"	2"	3
DWR 625-V-300	5/8"	3"	5
DWR 625-V-400	5/8"	4"	7



SPECIFICATIONS FOR SOFFIT VENTILATION TRIM

VENT AREA GRAPH

REVEAL WIDTH	VENT SLOTS PER ROW	VENT AREA PER FOOT
½"	1	1" Sq.
⅝"	1	1" Sq.
¾"	1	1" Sq.
⅞"	1	1" Sq.
1"	1	1" Sq.
1 ½"	2	2" Sq.
2"	3	3" Sq.
2 ½"	3	3" Sq.
3"	5	5" Sq.
4"	7	7" Sq.
6"	9	9" Sq.

It is possible to punch Vent Slots into many of Flannery's Trims, thus providing the needed ventilation for any project. All Vent Slots are ⅛" wide and 1" long. Vent Slots are configured at 1½" on center lengthwise and ½" on center laterally. Each row of Vent Slots lengthwise provides approximately one-square inch of vented area per lineal foot (see Vent Area Graph). All of Flannery's Vented Trims are available with a charcoal fiberglass bug screen to prevent insects from entering the soffit area through the vent slots. Bug screen is available upon request at an additional cost.

Flannery manufactures ventilated trims for a number of soffit systems including, Plaster, EIFS, Exterior Gypsum Board and Wood Paneling. Attach Vent Screeds to the framing with nails, screws, or other approved fastening methods. All Vent Screeds must be cut accurately and installed with tight, neat joints. Please specify Flannery Product Code along with the phrase "with Vent" (i.e. "PCS 75-V-200 with Vent") when ordering Vent Screeds.

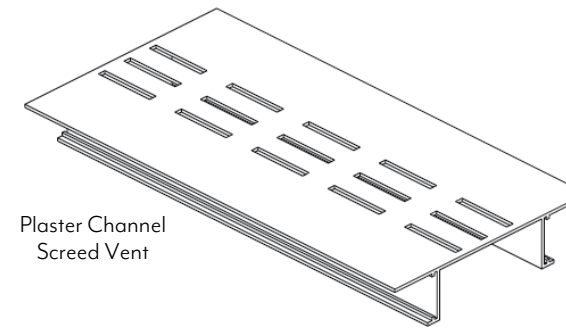

Plaster Channel Screed Vent

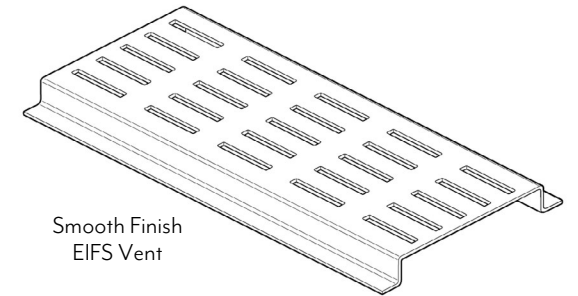

Smooth Finish EIFS Vent

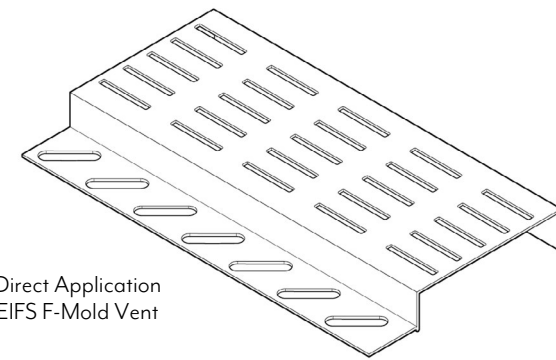

Direct Application EIFS F-Mold Vent

EXTERIOR PANEL TRIM SHAPEFINDER

The following section outlines the many different trim profiles that Flannery manufactures for exterior panel systems including Fiber Cement Panels and Composite Siding Materials. These trim products will fit a variety of panel thicknesses including 5/16" thick cement panels all the way up to 1-1/4" thick composite siding products. Trim options vary from horizontal and vertical reveals to corner trims and aluminum furring (or batten) strips. Many of these products are stocked in a factory primed finish. Other factory finishes are available and can be viewed on pages 44-45 of this brochure.

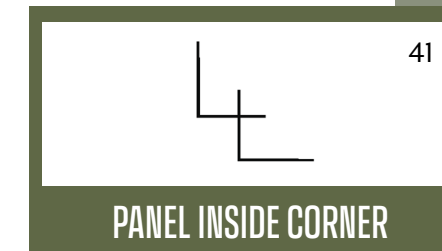
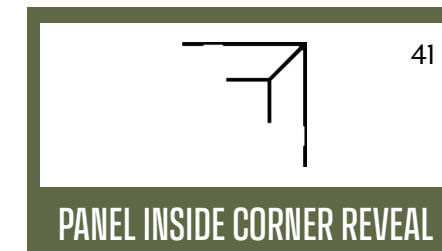
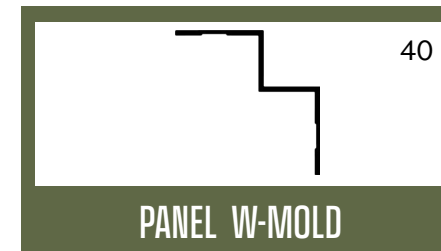
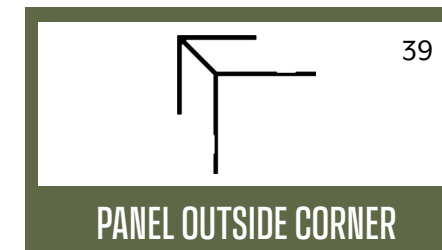
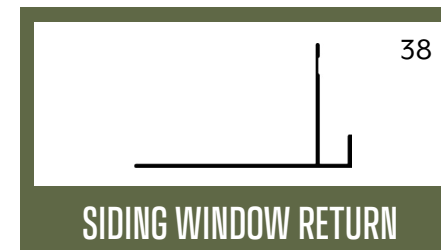
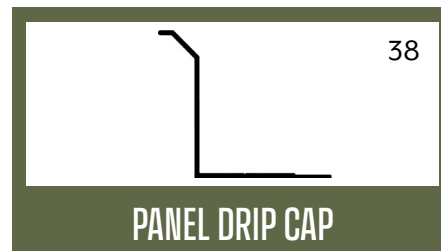
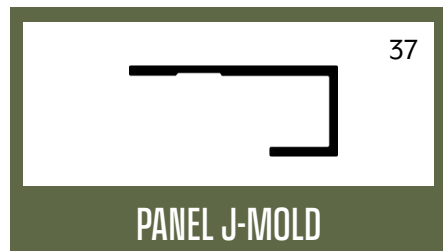
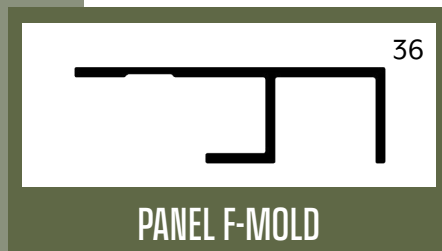
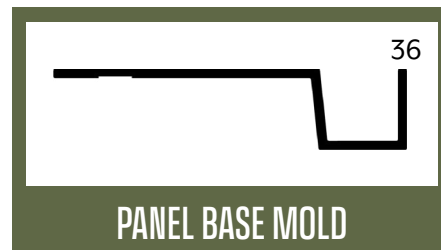
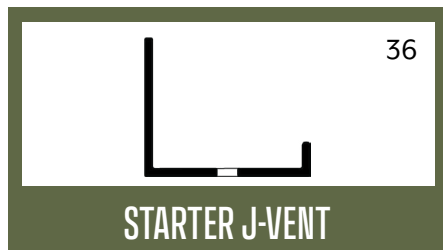
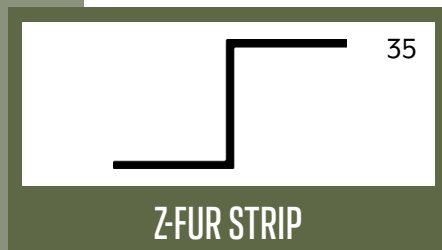
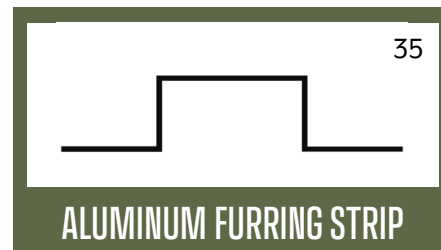
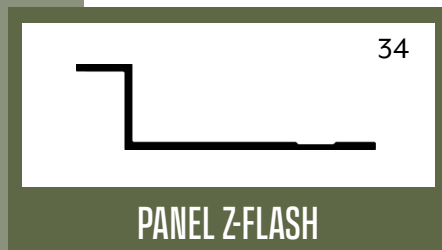
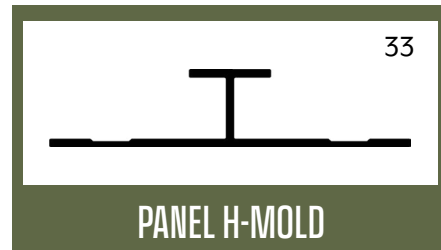
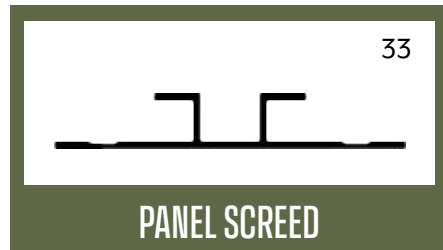
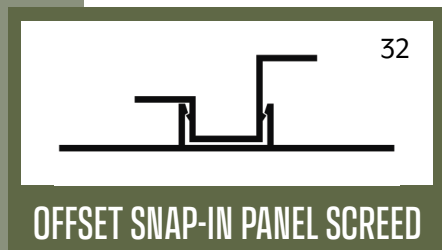
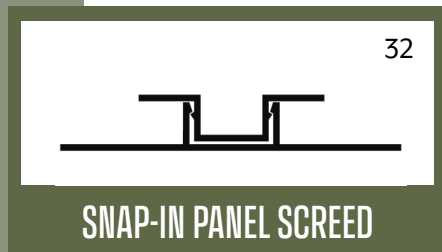

SNAP-IN PANEL SCREED

Flannery's Snap-In Panel Screeds create a vertical reveal between two panels and are unique because they allow for an easier installation of a vertical reveal when used with paneling since the Base of the Snap-In Panel Screed is installed prior to the paneling. Once the paneling is installed the reveal can be "snapped-in" to the base saving the installer the trouble of having to tuck the panels in under the trim flanges. ****Please Note:** Flannery's Snap-In Panel Screed must not be used as a horizontal reveal.

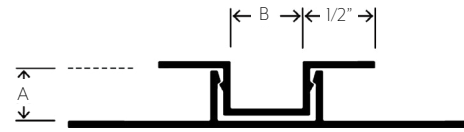

PART NO.	"A" DEPTH	"B" WIDTH	PANEL SIZE
SCPS 375-50	3/8"	1/2"	3/8"
SCPS 75-50	3/4"	1/2"	3/4"

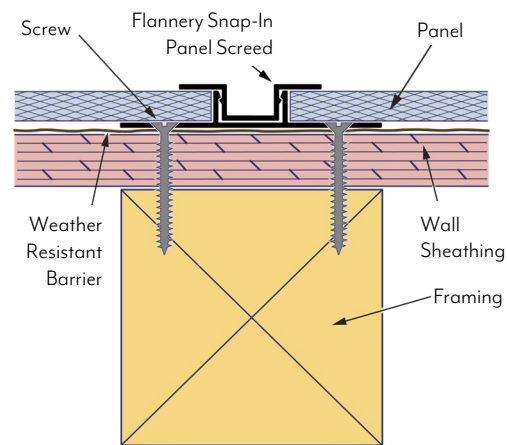

SNAP-IN OFFSET PANEL SCREED

Flannery's Snap-In Offset Panel Screed creates a vertical reveal between 3/8" and 3/4" thick panels and utilizes a two-piece system to achieve it. Because this is a snap-in trim, installation is easier since the reveal can be "snapped-in" after the base and the paneling is installed. This saves the installer trouble of having to tuck the panels under the trim flanges. ****Please Note:** Flannery's Snap-In Offset Panel Screed must never be used as a horizontal reveal.

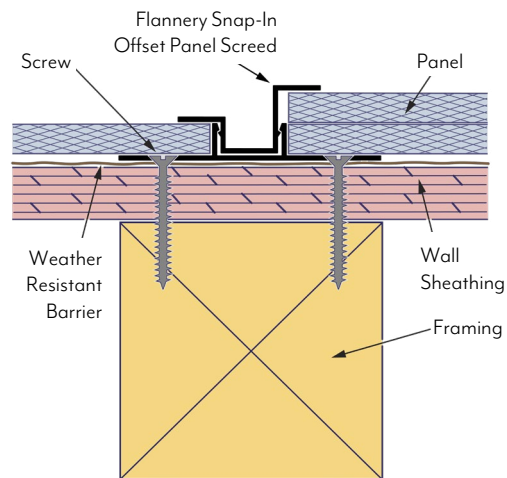
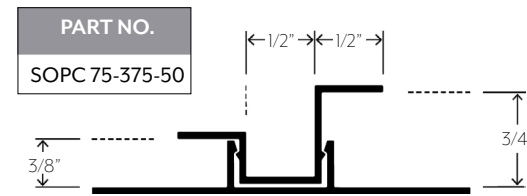

PANEL SCREED

Flannery's Panel Screed creates a clean vertical reveal between two Panels. This is an attractive alternative to butting one panel to another, so the design is clean and has an aesthetic feel. ****Please Note:** Panel Screeds are not recommended to be installed horizontally as it is an exterior product and can trap water if not installed vertically.

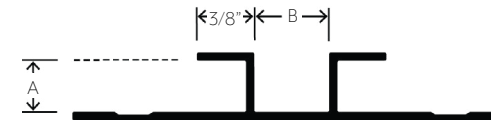

PART NO.	"A" DEPTH	"B" WIDTH	PANEL SIZE
CPS 375-50	3/8"	1/2"	3/8"
CPS 50-50	1/2"	1/2"	1/2"
WPR75-375-50	3/4"	1/2"	3/4"

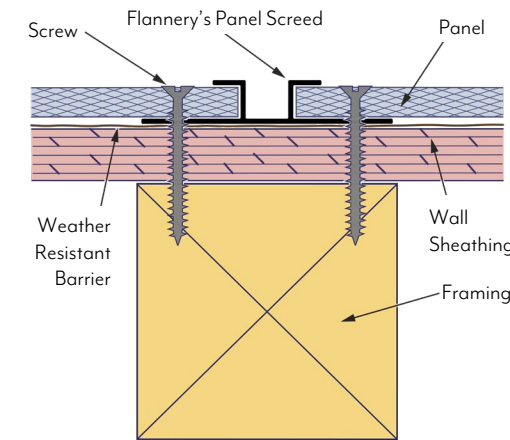

PANEL H-MOLD

Flannery's Panel H-Mold creates a vertical "flat-face" reveal between two adjoining Panels and is an attractive alternative to butting one panel to another. ****Please Note:** Flannery's Panel H-Mold should not be used as a horizontal reveal.

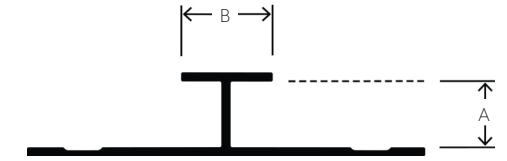

PART NO.	"A" DEPTH	"B" WIDTH	PANEL SIZE
CPH 375-50	3/8"	1/2"	3/8"
SHM 625-100	5/8"	1"	5/8"
WPH 75-375	3/4"	3/8"	3/4"
WPH 75-50	3/4"	1/2"	3/4"
WPH 875-375	7/8"	3/8"	7/8"
SHM 875-100	7/8"	1"	7/8"
SHM1125-1250	1 1/8"	1 1/4"	1 1/8"
SHM1250-100	1 1/4"	1"	1 1/4"
WPH1417-375	1 13/32"	3/8"	1 13/32"

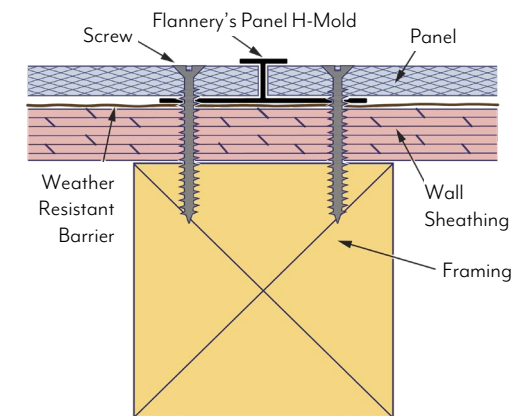

PANEL Z-FLASH

Flannery's Panel Z-Flash creates a horizontal reveal between two panels and assists in moving moisture out from behind the panel and away from the weather resistant barrier.

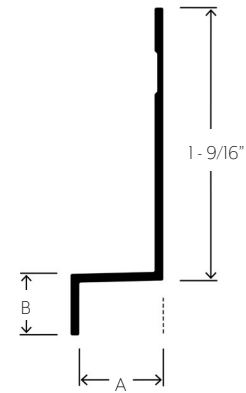

PART NO.	"A" DEPTH	"B" WIDTH	PANEL SIZE
CPZ 50	1/2"	3/8"	1/2"
CPZ 625	5/8"	3/8"	5/8"

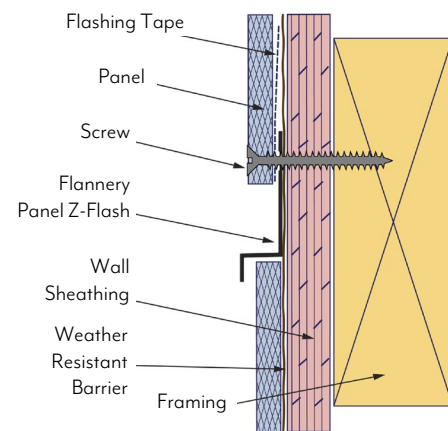

PANEL HORIZONTAL REVEAL

Flannery's Panel Horizontal Reveal creates a horizontal reveal between two Panels and mimics the vertical Panel Screed. The Panel Horizontal Reveal is an attractive alternative to the standard Panel Z-Flash and offers a shelf for the cement panels to rest on.

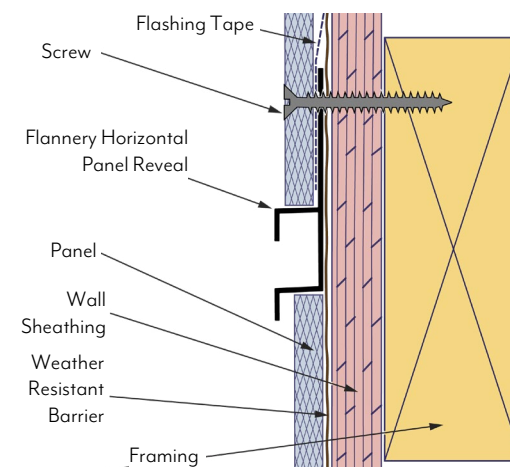
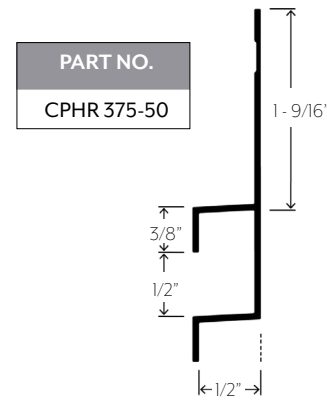

ALUMINUM FURRING STRIP

Flannery's Aluminum Furring Strip is designed to hold panels or composite siding away from the substrate in order to allow for the movement of air behind the panels. Since our furring strips are manufactured with aluminum, they will never rot or rust out from behind the wall system.

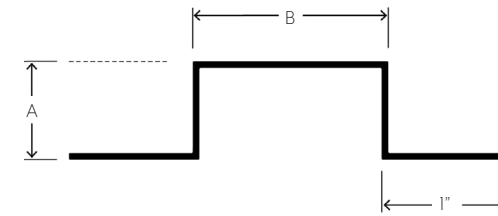

PART NO.	"A" DEPTH	"B" WIDTH
FUR 375-100	3/8"	1"
FUR 75-150	3/4"	1 1/2"

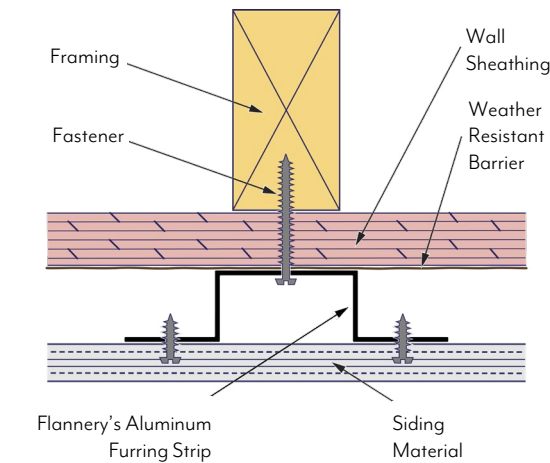

Z-FUR STRIP

Flannery's Z-Furring Strips were designed to hold panels or composite siding away from the substrate in order to allow for the movement of air behind the panels. The Z-Fur strips are an extruded aluminum product, which means they will never rot or rust out from behind the wall system.

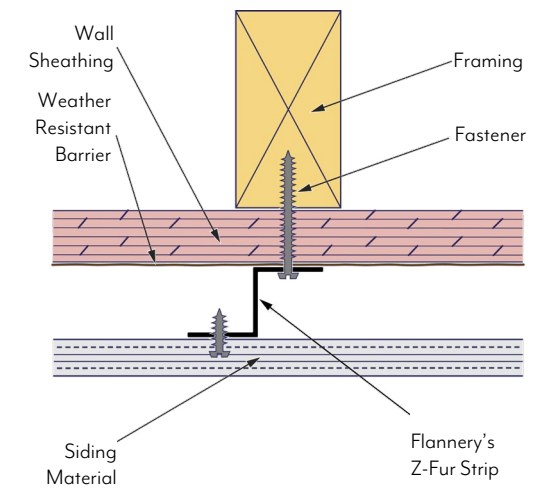
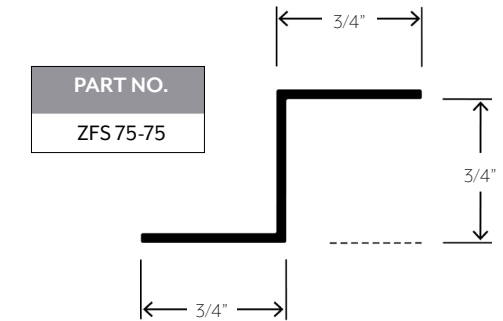

STARTER J-VENT

Flannery's Starter J-Vent is a siding trim which is designed to enable a panel installer to hang the first level of a siding or panel to a vertical wall while also allowing for air flow behind the panels system.

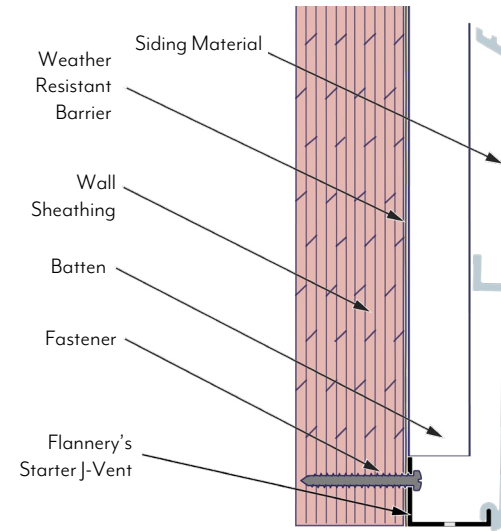
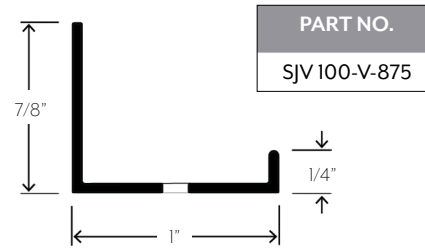

PANEL BASE MOLD

Flannery's Panel Base Mold creates an aesthetic horizontal line at the bottom of a panel wall system. The top of the Panel Base Mold is sloped to allow moisture to run off of the top of the trim. Works with panels that are 3/8" thick or less.

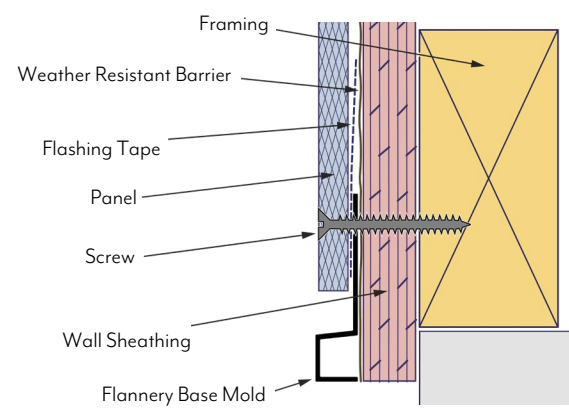
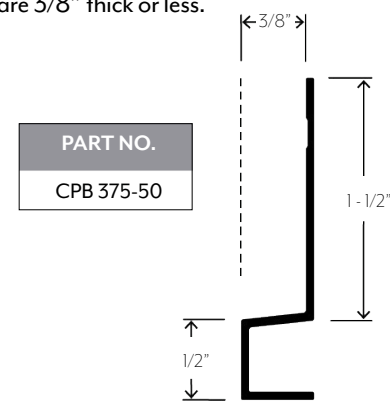

PANEL F-MOLD

Flannery's Panel F-Mold creates an aesthetic termination reveal between a panel and a dissimilar material. The Panel F-Mold is an attractive alternative to butting one cement panel to a dissimilar wall, door or window frame.

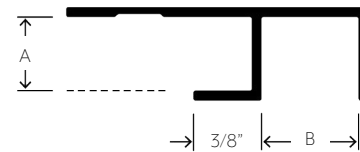

PART NO.	"A" DEPTH	"B" WIDTH	PANEL SIZE
CPF 375-50	3/8"	1/2"	3/8"
CPF 50-50	1/2"	1/2"	1/2"
WPF75-375-50	3/4"	1/2"	3/4"

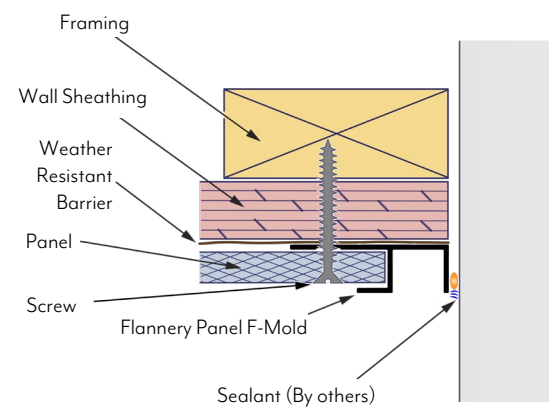

PANEL J-MOLD

Flannery's Panel J-Mold is an edge trim, which helps finish panels that terminate against dissimilar materials such as doors or windows.

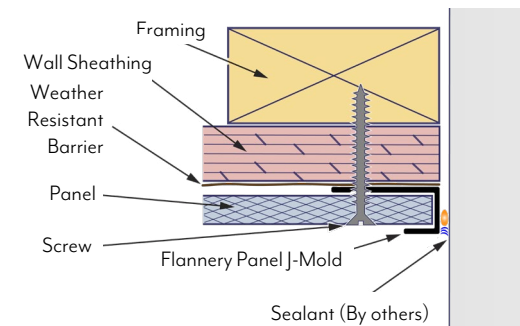
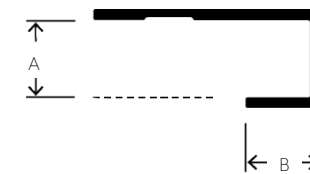

PART NO.	"A" DEPTH	"B" WIDTH	PANEL SIZE
CPJ 375-375	3/8"	3/8"	3/8"
CPJ 50-375	1/2"	3/8"	1/2"
SJM 460-50	29/64"	1/2"	29/64"
SJM 625-100	5/8"	1"	5/8"
WPJ 75-375	3/4"	3/8"	3/4"
WPJ 75-50	3/4"	1/2"	3/4"
SJM 80-50	4/5"	1/2"	4/5"
SJM 875-100	7/8"	1"	7/8"
SJM 1063-375	1 1/16"	3/8"	1 1/16"
SJM 1125-1250	1 1/8"	1 1/4"	1 1/8"
SJM 1250-50	1 1/4"	1/2"	1 1/4"
WPJ 1417-188	1 13/32"	3/16"	1 13/32"

PANEL DRIP CAP

Flannery's Panel Drip Cap is a horizontal edge trim that creates an aesthetic reveal between two panels or where a panel is installed over a door or window. It assists in moving moisture out from behind panels and away from the weather resistant barrier.

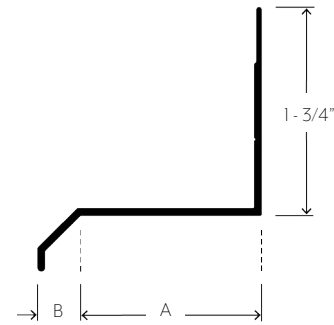

PART NO.	"A" DEPTH	"B" DEPTH	PANEL SIZE
CPD 625	5/8"	1/4"	5/8"
CPD 1250	1 1/4"	1/4"	1 1/4"

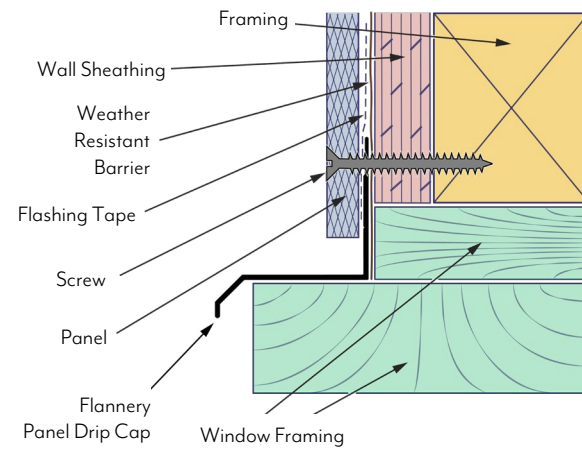

SIDING WINDOW RETURN

Flannery's Siding Window Return creates an aesthetic termination point where a panel wall terminates at a recessed frame. The Siding Window Return eliminates the need for a small panel return where the wall terminates at the recess of a window opening. Fits Panels that are 7/16" thick.

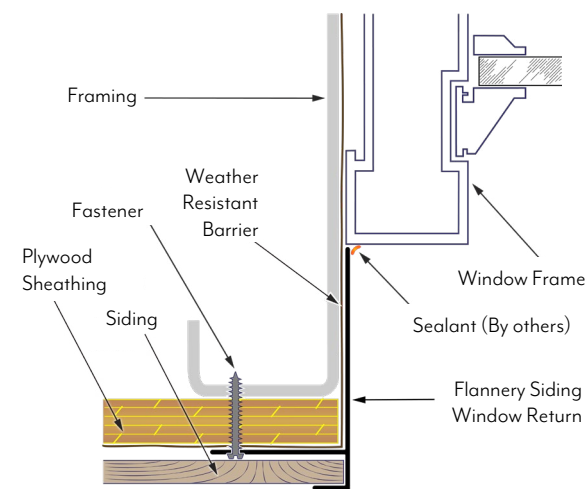
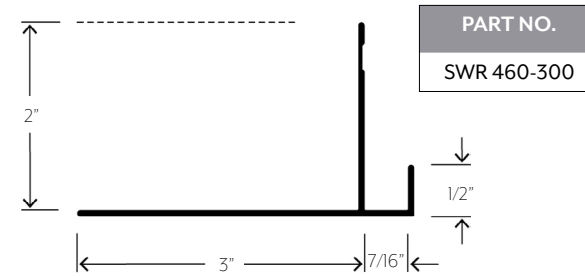

PANEL X-MOLD

Flannery's Panel X-Mold is an outside corner trim that creates an aesthetic reveal where two panels come together at an outside 90° corner. The face flange on each side covers the edge of the panels without requiring them to be mitered at the edge.

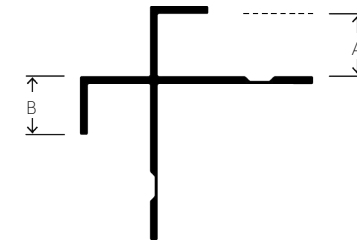

PART NO.	"A" DEPTH	"B" WIDTH	PANEL SIZE
CPX 375-375	3/8"	3/8"	3/8"
CPX 50-375	1/2"	3/8"	1/2"
SXM 625-100	5/8"	1"	5/8"
WPX 75-375	3/4"	3/8"	3/4"
SXM 80-50	4/5"	1/2"	4/5"
SXM 875-100	7/8"	1"	7/8"
SXM 1125-1250	1 1/8"	1 1/4"	1 1/8"
SXM 1250-50	1 1/4"	1/2"	1 1/4"

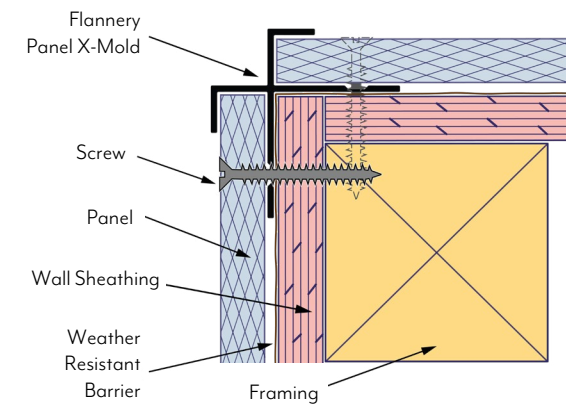

PANEL OUTSIDE CORNER

Flannery's Panel Outside Corner is an outside corner trim that creates a sharp aesthetic corner where two panels come together at an outside 90° corner. The face flange on each side covers the edge of the panels and may require them to be mitered at the edge.

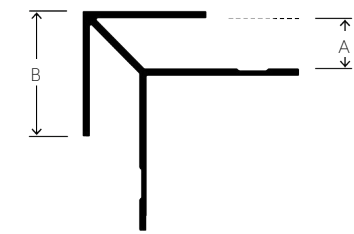

PART NO.	"A" DEPTH	"B" WIDTH	PANEL SIZE
CPOC 375-100	3/8"	3/8"	3/8"
SOC 460-100	7/16"	1"	7/16"
SOC 625-100	5/8"	1"	5/8"
WPOC 75-375	3/4"	3/8"	3/4"
WPOC 75-150	3/4"	1 1/2"	3/4"
SOC 80-150	4/5"	1 1/2"	4/5"
SOC 875-100	7/8"	1"	7/8"
SOC 1250-150	1 1/4"	1 1/2"	1 1/4"

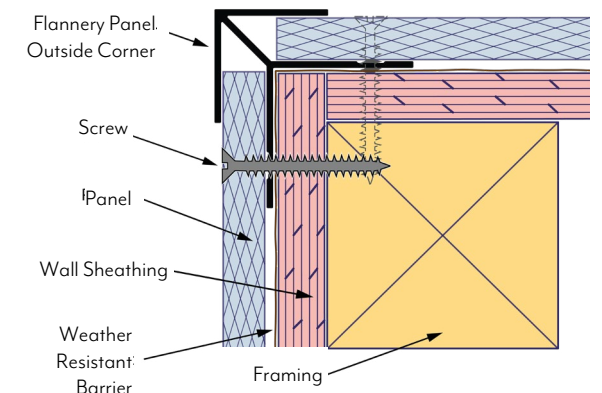



PANEL W-MOLD

Flannery's Panel W-Mold is an inside corner trim that creates a termination point between two Panels that meet at an inside 90° corner.

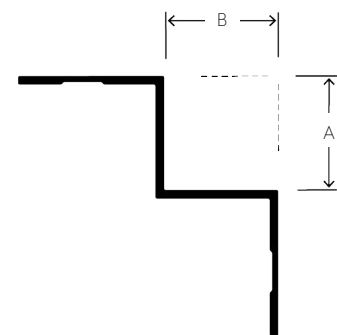

PART NO.	"A" DEPTH	"B" WIDTH	PANEL SIZE
CPW 50-50	1/2"	1/2"	1/2"
CPW 625-625	5/8"	5/8"	5/8"
WTM 75-75	3/4"	3/4"	3/4"

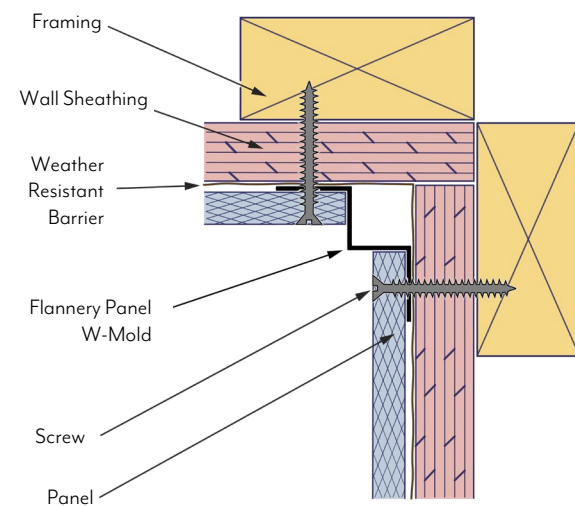

PANEL INSIDE CORNER REVEAL

Flannery's Panel Inside Corner Reveal creates an aesthetic termination reveal between two Panels that meet at an inside 90° corner. The Panel Inside Corner Reveal is an attractive alternative to simply butting two panels against one another at an inside corner.

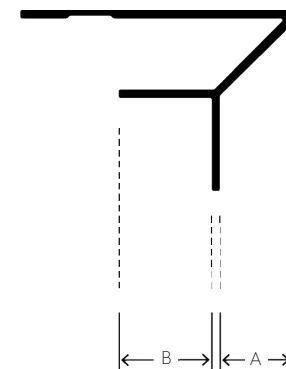

PART NO.	"A" DEPTH	"B" WIDTH	PANEL SIZE
SIC 625-100	5/8"	1"	5/8"
SIC 875-100	7/8"	1"	7/8"

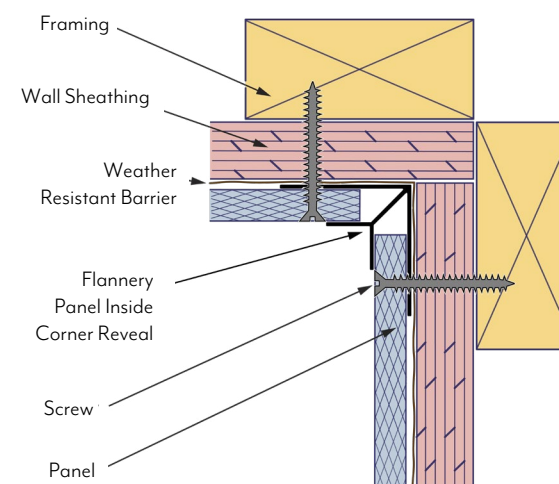

PANEL INSIDE CORNER

Flannery's Panel Inside Corner trim creates a sharp and crisp corner where siding is installed on walls that meet at a 90° inside corner joint. The Inside Corner trim creates a solid and clean corner for the siding system which would normally require the two pieces of siding to be laid together at an inside corner.

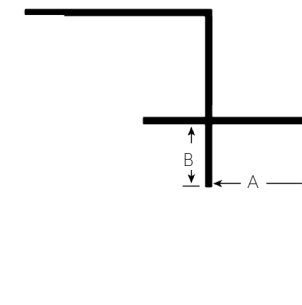

PART NO.	"A" DEPTH	"B" WIDTH	PANEL SIZE
CPIC 375-50	3/8"	1/2"	3/8"
SIC 460-50	7/16"	1/2"	7/16"
SIC 80-50	1/5"	1/2"	1/5"
WPIC 75-375	3/4"	3/8"	3/4"
SIC 1250-50	1 1/4"	1/2"	1 1/4"

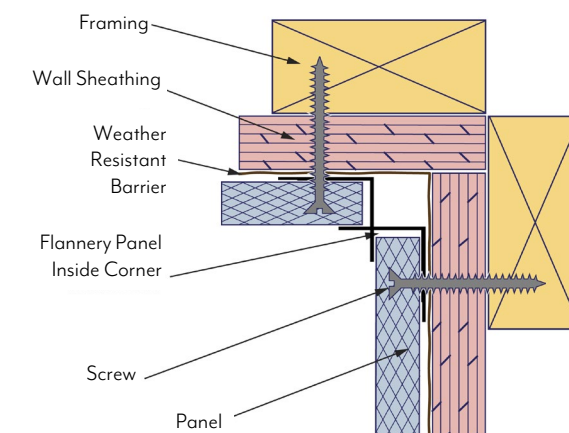

SPECIFICATIONS FOR PANEL TRIMS

INTERIOR USAGE

Flannery recommends that any installer of Aluminum Panel Trims properly layout and coordinate the install of trims along with the particular paneling that will be utilized in a given installation. Proper planning will reduce installation time and produce the desired design aesthetic.

EXTERIOR USAGE

It is important for the installer to be aware of certain restrictions when installing Aluminum Panel Trims on an exterior wall. Certain trims are designed specifically for vertical or horizontal installation to allow for the proper movement of moisture around the paneling. Trim installed improperly could lead to moisture intrusion or a poor wall design. Please refer to flannerytrim.com for a more comprehensive installation guide of exterior panel trims.

WHEN INSTALLING EXTERIOR PANEL TRIMS VERTICALLY

Weather resistant barrier must be placed behind all moldings and have a shiplap of 6". Attach moldings 16" on center to framing using approved fastening methods. Butt joints must be cut accurately and sealed.

WHEN INSTALLING EXTERIOR PANEL TRIMS HORIZONTALLY

Weather resistant barrier must be placed behind all moldings and have a shiplap of at least 2". Flashing tape may be required over the upper attachment flange of trims running horizontally as an avenue for moisture to flow out from behind the system. Attach moldings 16" or 24" on center to the framing using approved fastening methods. Butt joints must be cut accurately and sealed.

USE OF PANEL TRIMS WITH FIBER CEMENT PANELING

Whenever aluminum trims are used with Fiber Cement Panels, it is important that all trims be coated with a finish to protect the metal from the acidity of the panels. These coatings can include an Anodized finish, liquid or powder coat paint, primer or a chem-film finish. You can explore all of our finishing options on pages 44-45.

PANEL TRIM ALLOY & COMPOSITION

Flannery's Panel Trims are standard extruded aluminum alloy 6063 T5 and have a typical .050" nominal wall thickness. Aluminum Panel Trims are aesthetic trims which are not intended to hold or support the weight of any panel system. Please consult a structural engineer when considering the use of Flannery Furring Strips or Z-Fur Strips in a rainscreen system.

MANUFACTURER'S SPECIFICATIONS

PRODUCT SPECIFICATIONS

Flannery recommends that any installer of our Aluminum Trims properly layout and coordinate the installation of trims along with materials that will be utilized in the installation of the exterior wall system.

FLANNERY ALUMINUM TRIM ALLOY & COMPOSITION

Flannery's Aluminum Trims are standard extruded aluminum alloy 6063 T5 and have a typical .050" or greater nominal wall thickness. Extruded Aluminum Trims are aesthetic trims which are not intended to hold or support the full weight of any Panel, Stucco, or Plaster system. Flannery's Trims meet or exceed ASTM B221 for extruded aluminum products.

Flannery's Aluminum Trims come in 10' lengths typically and shall have a standard stock finish of Mill Finish (for field priming & painting) or Clear Anodized (some may be stocked in Black Anodized). Other factory finishes including liquid or powder coated paint, Chem-Film, Primer and special Anodizing finishes are available. All of our other finishing options can be viewed on the next page.

HANDLING ALUMINUM TRIMS

Personal protection equipment should be utilized when handling and installing aluminum trims. Gloves and eye protection must be worn when handling aluminum trims as well as ear protection when cutting.

CUTTING ALUMINUM MOLDINGS

Flannery recommends that ten-foot lengths be used wherever possible. Aluminum Moldings can be cut with a chop saw, using a 125-150-tooth carbide-tip blade for non-ferrous metal. An abrasive cut-off wheel should not be used to cut aluminum trims. Blade lubricant (WD-40 or grease stick) must be applied to the blade before each cut. Lubricant should be cleaned from the trim prior to installation.

STEPS FOR FIELD PAINTING MILL FINISH (RAW) ALUMINUM MOLDINGS

1. Clean and treat moldings in accordance with the paint manufacturer's specifications.
2. Use a primer recommended by the paint manufacturer's specifications.
3. Apply paint coat according to the paint manufacturer's specifications.
4. Flannery makes no guarantees, nor accepts any responsibility, for the performance of field-applied coatings over anodized finishes.
5. If aluminum trim has an alternate finish, contact Flannery for field painting instructions.

FACTORY FINISHES

MILL FINISH

“Mill Finish” is the term that Flannery uses to describe its aluminum trims that have no finish applied to them. In other words, it is raw aluminum from our mill and can be field primed and painted. Typically, Mill Finish has a shiny or “mirror-like” appearance with some visible manufacturing lines.

Mill Finish trims must be cleaned before field priming. Typically, soapy water can clean most oils or production residue from the surface of the trim. Sufficient drying time should be planned for before primer is applied. The paint manufacturer should be consulted when choosing a primer for aluminum trims. Mill Finish trims should never be left exposed for an extended period of time, since this may allow the metal to begin the oxidation process.

KYNAR® PAINT FINISH

Kynar® is a 70% fluoropolymer resin based 2-coat baked on paint that is offered by Flannery and can be used where high durability is needed or an existing color must be matched. Kynar® finishes are highly resistant to chalking & ultraviolet deterioration. They are also highly resistant to chemicals, salt spray, and industrial pollutants.

Flannery recommends these finishes for trims on exteriors in harsh environments including coastal areas where salt air is most common. Kynar® paint finishes are available in custom colors. Please note that some finishes will require a Kynar® XL (with topcoat) finish due to the exotic nature of the color. Have the color code or sample available when requesting a quote for custom colors.

Kynar® Paint Finishes shall meet or exceed AAMA 605.2 Specification “Voluntary Specification for High

Performance Organic Coatings on Architectural Extrusion Panels.” Meets or exceeds a nominal dry film thickness of 1.2 mil. (Kynar® is a registered trademark of Atochem North America, Inc).

POWDER COATED PAINT FINISHES

Flannery offers Powder Coated Paint Finishes on all its aluminum trims. Flannery’s factory powder-coated paint process can match any paint manufacturer’s number or match a custom paint color to provide the desired aesthetic finish. Powder-coated paint finishes are applied to aluminum trims after a factory primer has been applied. Have the color code or sample available when requesting a quote for custom colors.

Powder-Coated Paint finishes shall meet or exceed the dry film thickness of 1.2 mil as specified in AAMA 2605 SEC 4.3. Color uniformity will meet or exceed the requirements of AAMA 2605 SEC 7.1.

POWDER COATED “WOOD GRAIN”

Flannery is also able to offer Powder-Coated “Wood Grain” Finishes on all its aluminum trims to mimic the color and grain of real wood. This two-step finishing process where the trims are powder coated and then “impregnated” with a wood grain effect will allow any of our aluminum trims to appear to be a wood finish. Samples can be provided by Flannery for approval or wood finishes can be matched to job requirements.

CHEMICAL CONVERSION FINISH

Chem-film (aka Alodine) is a chemical conversion process that prepares aluminum extrusions for factory priming and painting. It is a multi-step cleaning and aluminum preparation process. First, it cleans the aluminum trim and then it acts as a protective coating until primer and paint

can be applied. If your job requires field painting, a chemical conversion coating can be specified. Chem-film Treatment or Alodine treatment of aluminum moldings shall conform to ASTM D1730 Type B and MIL-C-5541A.

FACTORY PRIMER

Flannery offers a Factory Primer option to reduce labor in the field. Flannery’s Trims can be ordered with a pre-applied primer from PPG Duranar known as Flash Primer. It typically is a yellowish color and is applied via conventional spray and then baked on.

Factory Primer is a conversion coating and applied per ASTM D1730, Type B, Method 5 or 7; processing per ASTM B449, Section 5. Dry film thickness of 0.20 - 0.30 Mils.

CLEAR ANODIZED

A standard finish for aluminum trims that is available is a Clear Anodized Finish (Architectural 200R1). The Clear Anodized finish is an electrochemical conversion process that deposits an oxide film on the aluminum trim. A natural oxidation process occurs on bare aluminum, however producing the oxidation process artificially creates a thicker, harder, and more durable “oxide film.” The Clear Anodized finish is an extremely durable finish and is resistant to most forms of corrosion. Standard Clear Anodized Finish-Architectural 200R1 medium etch (AA-M32C10A21). Thickness of anodic coating will be tested in accordance of ASTM B-244-68.

COLOR ANODIZING

Special Color Anodized finishes are also available if required. Gold Anodized, Black Anodized, and Bronze

Anodized finishes can be ordered. Bronze Anodized can be ordered in three different color shades: Light, Medium, and Dark Bronze. Please note: Color Anodized Finishes can vary from one piece of trim to another. This is one of the characteristics to the anodizing process and must be considered before any orders are placed. Typically, the color of the anodizing will fall within a certain range, which usually is determined prior to anodizing. Ask Flannery for details. Color Anodized Finish-Two-step impregnated color Class II Architectural .40-.70 mils (AA-M12C22A33). Thickness of coating shall be tested in accordance with ASTM B244-68.

POLISHED ANODIZING

Flannery offers special “Brushed” or “Polished” anodized finishes that imitate finishes found on other types of metals including Stainless Steel, Brushed Stainless Steel, Brass and other metals. These types of anodized finishes require a sample of the desired finish to be submitted to Flannery for quote and minimum order quantities may apply. Some smaller reveals may not be available with these special finishes due to production restrictions.

NOTES

This brochure presents general guidelines and suggestions for the installation of Flannery trims and products. The purpose of these general guidelines and suggestions is to aid in a successful interior or exterior finish based on the Uniform Building Code and industry standards. No one catalog or brochure can address all of the unique specifics or installation details that occur from one project to another. Flannery recommends that every installer be familiar, or become acquainted with, common interior or exterior trim installation practices before installing any of Flannery's many trims and products. Flannery also recommends that the specifying architect, engineer, and general contractor be consulted with as well.

